

FW60

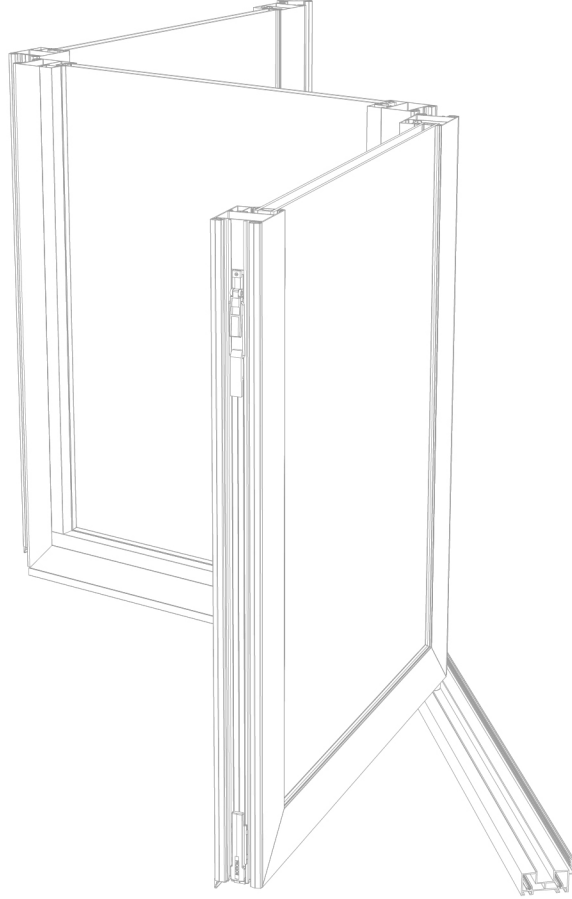

KATLANIR SİSTEM FOLDING SYSTEMS	FW 60	KASA	FRAME	100	FW60.15.101
		ORTA KAYIT	MULLION	200	
		KANAT	VENT	300	
		ADAPTÖR BAĞL. PR	ADAPTER	400	
		EPDM GRUP	EPDM GROUP	500	
		ACILIM GRUP	OPENING GROUP	700	

PROFİL ET KALINLIĞI	PROFILE THICKNESS	1,5-2,5mm
KASA YÜKSEKLİĞİ	FRAME HEIGHT	60mm
KANAT YÜKSEKLİĞİ	VENT HEIGHT	60mm
CAM KALINLIĞI	GLASS THICKNESS	4-36mm

ALAŞIM ÖZELLİKLERİ
ALLOY PROPERTIES

EN AW 6060 (AlMgSi0,5 F22)
EN AW 6063 (AlMg0,7Si F22)

ÜRETİM VE MEKANİK STANDARTLAR
PRODUCTION AND MECHANICAL STANDARDS

EN 12020-2 EN 755-9 EN 755-2

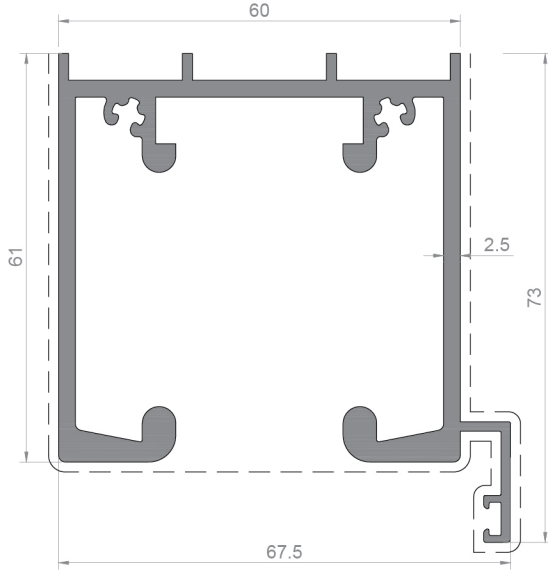
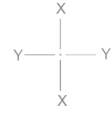

Kasa profili	Frame profile
FW60.15.101	
Weight : 1,970 kg/m	
Ix : 44,66 cm ⁴	Wx : 12,58cm ³
Iy : 34,44 cm ⁴	Wy : 8,14cm ³

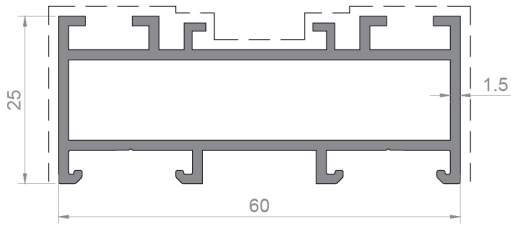

Kasa profili	Frame profile
FW60.15.102	
Weight : 0,822 kg/m	
Ix : 12,83 cm ⁴	Wx : 4,27 cm ³
Iy : 1,85 cm ⁴	Wy : 1,48 cm ³

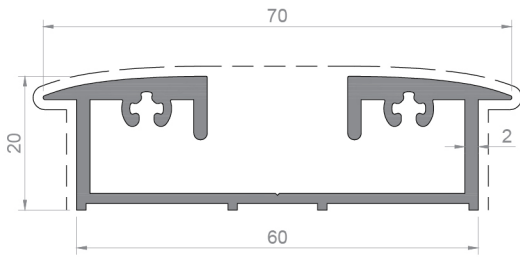

Kasa profili	Frame profile
FW60.15.103	
Weight : 0,900 kg/m	
Ix : 15,20 cm ⁴	Wx : 4,34 cm ³
Iy : 1,64 cm ⁴	Wy : 1,46 cm ³

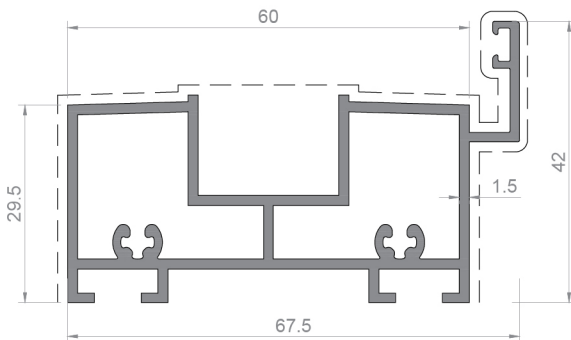

Kasa profili	Frame profile
FW60.15.104	
Weight : 1,150 kg/m	
Ix : 20,43 cm ⁴	Wx : 5,99cm ³
Iy : 4,42 cm ⁴	Wy : 1,68cm ³

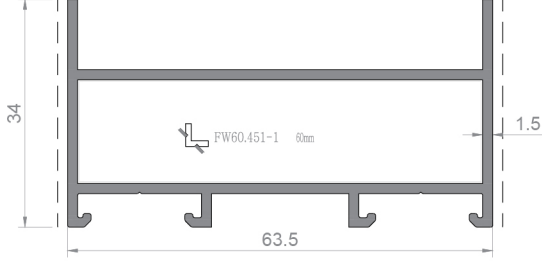
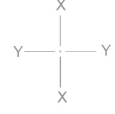

Kasa profili	Frame profile
FW60.15.105	
Weight : 0,845 kg/m	
Ix : cm ⁴	Wx : cm ³
Iy : cm ⁴	Wy : cm ³

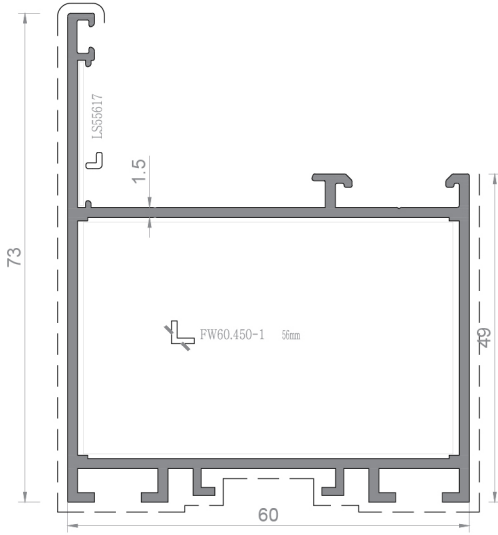

Kanat profili	Vent profile
FW60.15.301	
Weight : 1,147 kg/m	
Ix : 24,75 cm ⁴	Wx : 7,63cm ³
Iy : 15,79 cm ⁴	Wy : 3,43cm ³

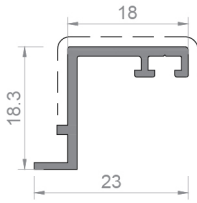

Kanat adaptör profili	Vent adapter profile
FW60.15.401	
Weight : 0,176 kg/m	

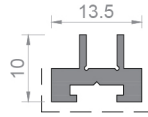

Kanat adaptör profili	Vent adapter profile
FW60.15.402	
Weight : 0,160 kg/m	

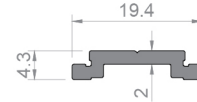

Tij pr.	Opening adapter
W55+ 15.434	
Weight : 0,130 kg/m	

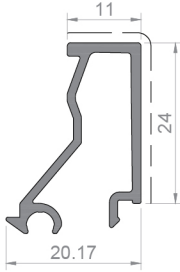
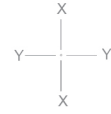

cam çitası pr.
glazing bead profile

LS55431

Weight : 0,282 kg/m

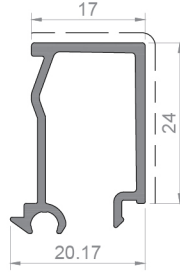

cam çitası pr.
glazing bead profile

LS55432

Weight : 0,294 kg/m

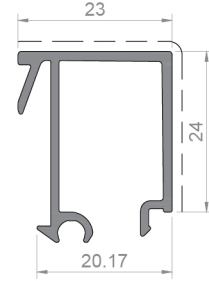

cam çitası pr.
glazing bead profile

LS55433

Weight : 0,341 kg/m

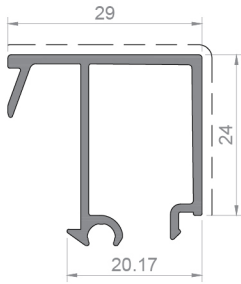

cam çitası pr.
glazing bead profile

LS55434

Weight : 0,363 kg/m

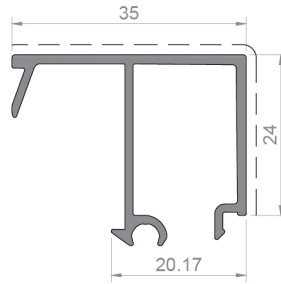

cam çitası pr.
glazing bead profile

LS55435

Weight : 0,385 kg/m

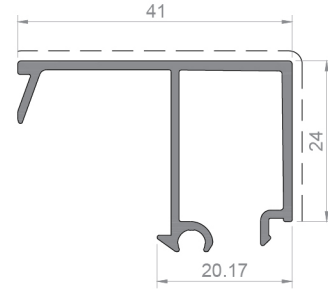

cam çitası pr.
glazing bead profile

LS55436

Weight : 0,408 kg/m

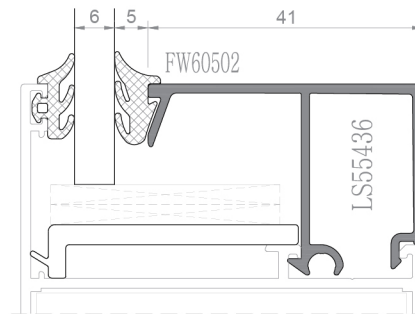
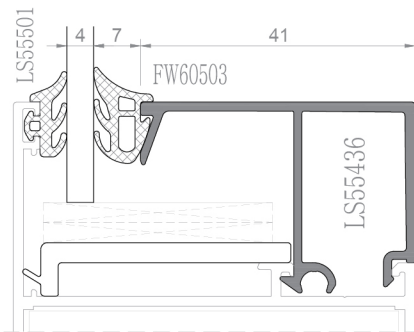

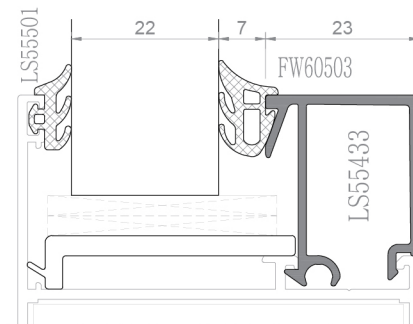
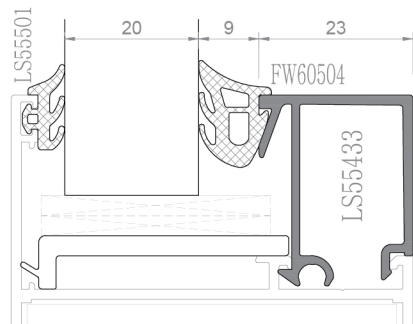
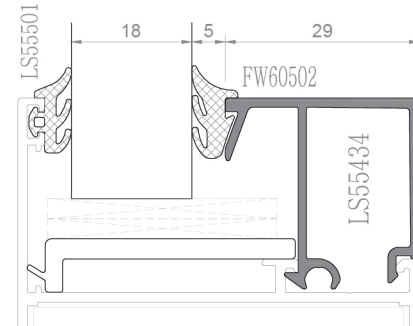
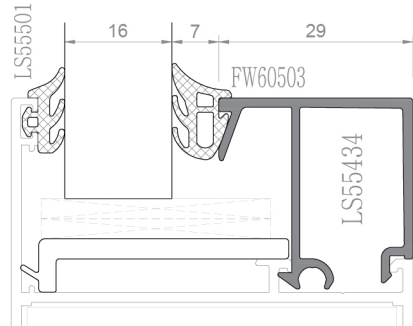
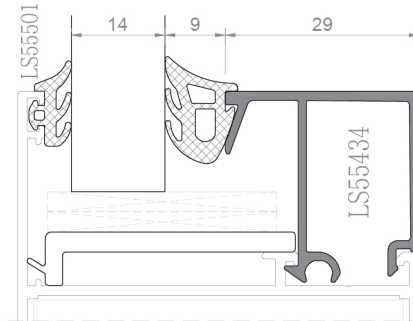
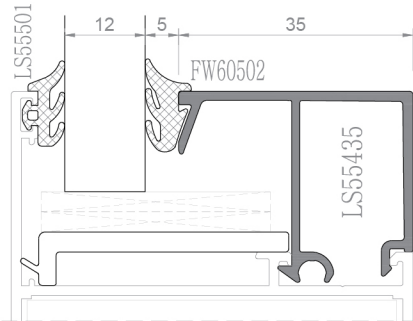
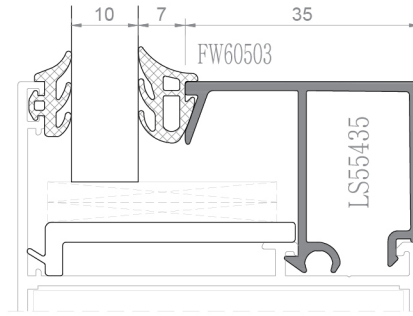
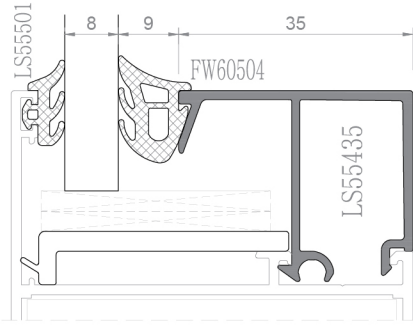

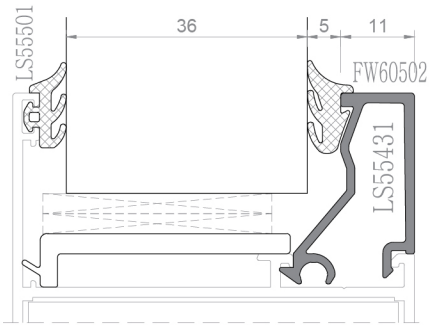
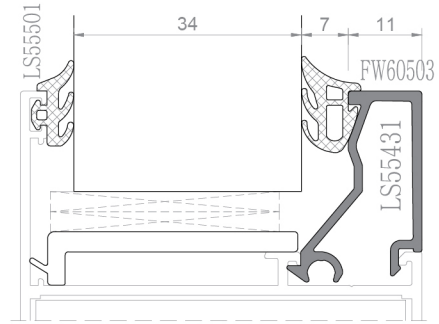
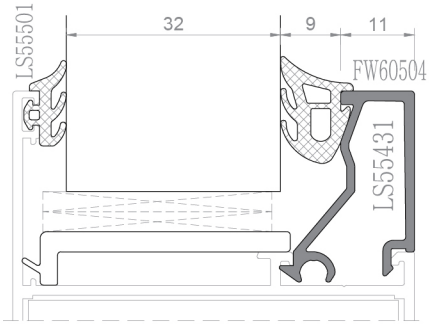
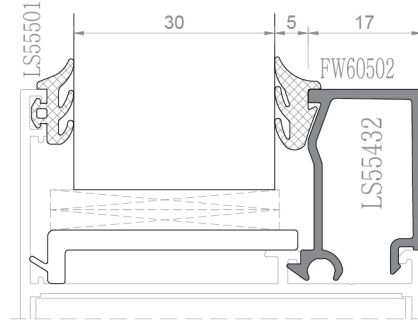
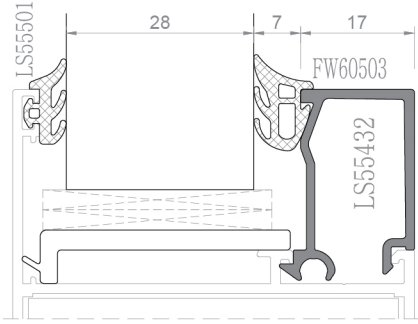
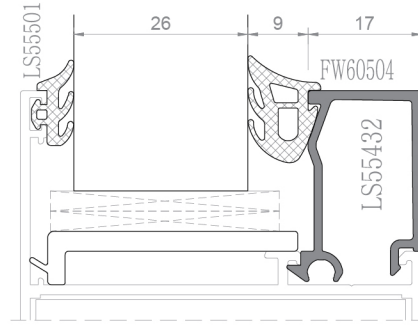
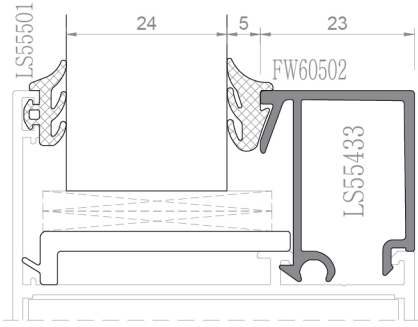

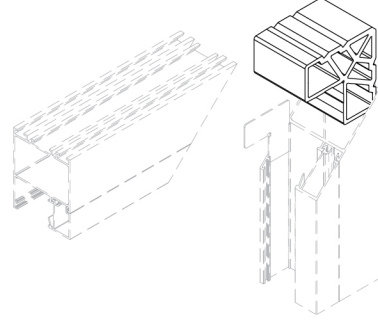
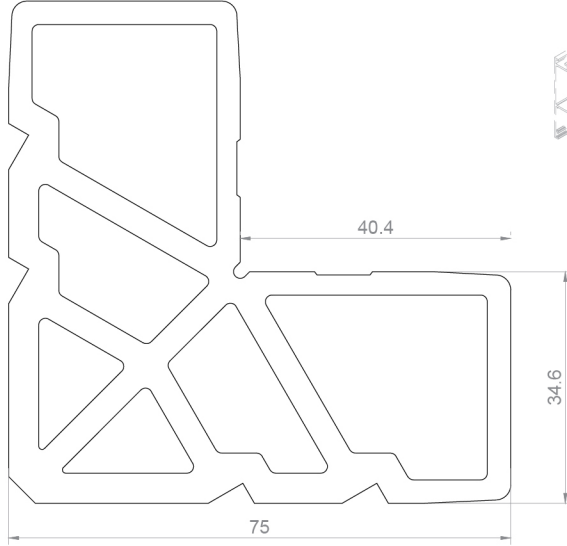



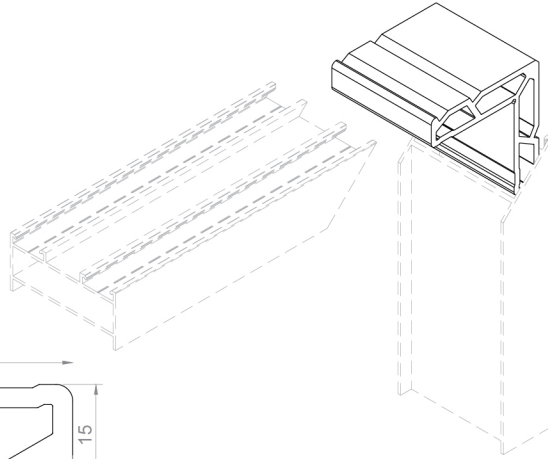
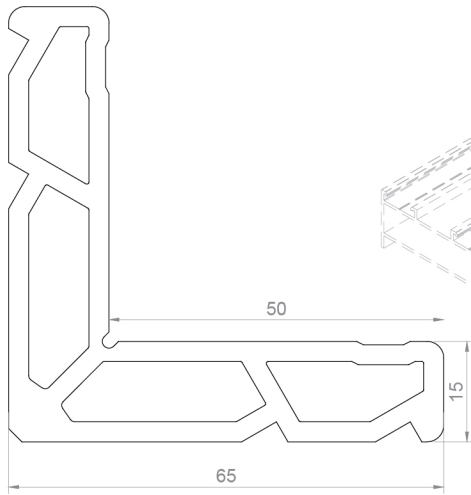

Kanat köşe takoz pr. <i>sash assembling Plug</i>
FW60.450
Weight : 4,505 kg/m
FW60.450-1 56mm

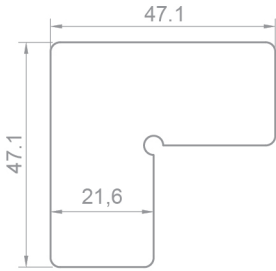
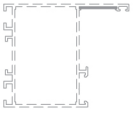

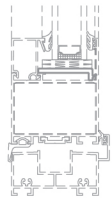
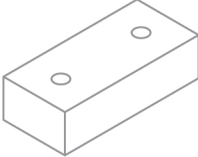
Kasa köşe takoz pr. <i>Fixed frame assembling Plug</i>
FW60.451
Weight : 4,505 kg/m
FW60.451-1 60mm

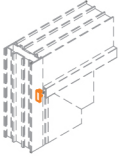
kod code	şekil drawing	tanım description	paket metrajı in one package metre / package	kullanım yeri application
LS55617		köşe onbaşı corner cleat for sash	200 pcs/pk	
FW60.610		cam destek pr. parçası glazing support	6,0 m 5 pcs/pk FW60.610-1 100mm 50 pcs/pk	
FW60.601		üst rulman destek takozu (pvc) support wedge	1 pcs/pk	
FW60.602		kasa yan kapak (pvc) frame side cover	10 pcs/pk	

kod code	şekil drawing	tanım description	teorik ağırlık teoretical weight gr/m	paket ağırlığı package weight kg/package	paket metraji in one package metre/package	kullanım yeri application
LS55501		epdm cam dış fitil glazing gasket outside	51 gr/m	15 kg	285 m	
FW60502		epdm cam iç fitil glazing gasket inside	64 gr/m	12 kg	187 m	
FW60503		epdm cam iç fitil glazing gasket inside	78 gr/m	12 kg	153 m	
FW60504		epdm cam iç fitil glazing gasket inside	94 gr/m	12 kg	127 m	
FW60505		epdm fitil epdm gasket	101 gr/m	12 kg	118 m	
FW60506		epdm fitil epdm gasket	30 gr/m	12 kg	400 m	
FW60507		epdm fitil epdm gasket	71 gr/m	10 kg	140 m	
FW60520		perdeli fırça fitil rabbet brush gasket	-	-	225 m/pk	

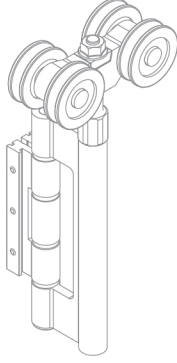

Rulmanlı üst menteşe
roller top hinge

FW60.701
siyah renk
(black)

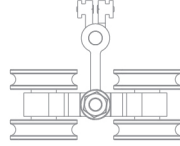

max.80 kg

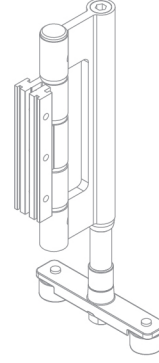

Rulmanlı alt menteşe
roller top hinge

FW60.702
siyah renk
(black)



Farklı renk seçeneği belirtilmelidir.
By selecting different colors, it must be informed.

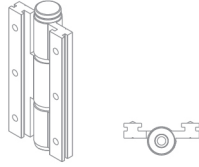

yaprak menteşe
leaf hinge

FW60.703
siyah renk
(black)

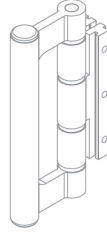

çekme menteşe
pulling hinge

FW60.704
siyah renk
(black)

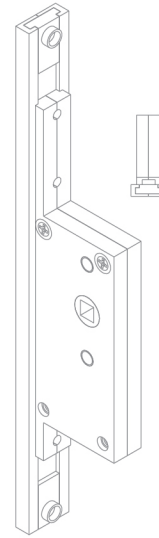

ispanyolet gövde
espagnolette body

FW60.705
siyah renk
(black)

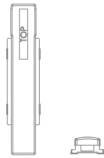

üst sürgü (pvc)
leaf hinge

FW60.706



alt sürgü (pvc)
leaf hinge

FW60.707

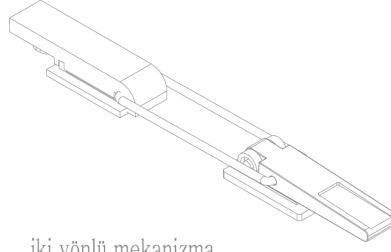

iki yönlü mekanizma
Two way mechanism and guide

FW60.708

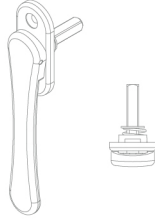

çekme kapı kolu
pull door handle

FW60.709

siyah renk
(black)



Farklı renk seçeneği belirtilmelidir
By selecting different colors, it must be informed.

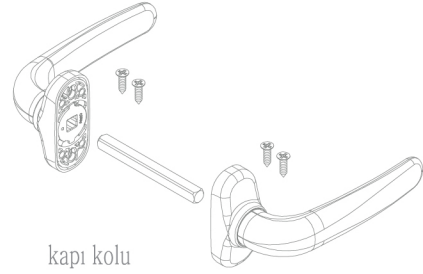

kapı kolu
door handle

FW60.710

siyah renk
(black)



Farklı renk seçeneği belirtilmelidir
By selecting different colors, it must be informed.

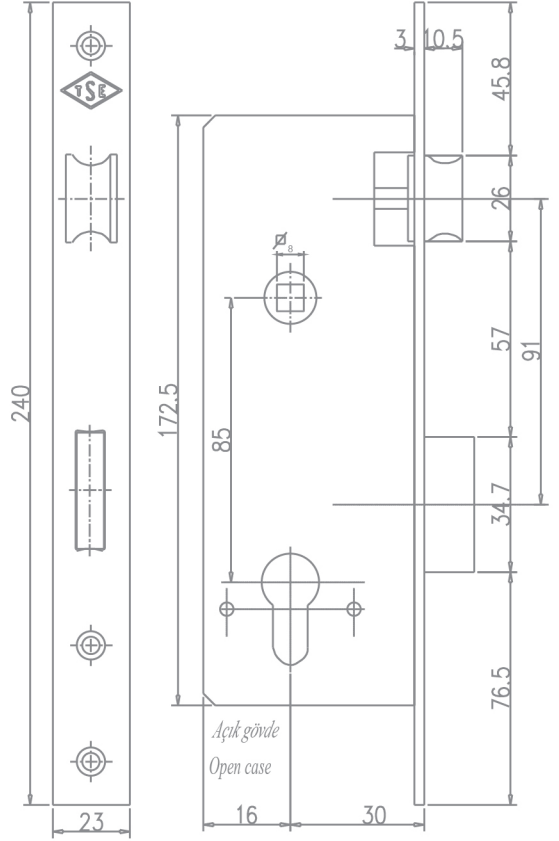

FW60.711

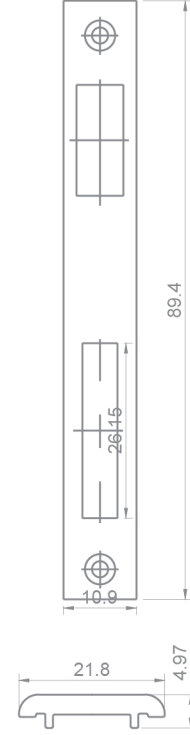

FW60.712

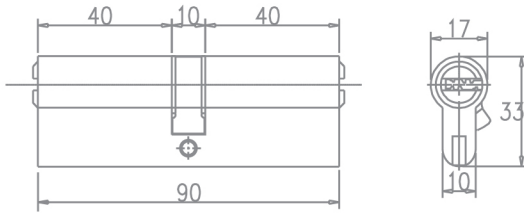

FW60.713 Barel
Cylinders



FW60.714

siyah renk
(black)

Barel rozeti
Cylinder cover



Farklı renk seçeneği belirtilmelidir.
By selecting different colors, it must be informed.

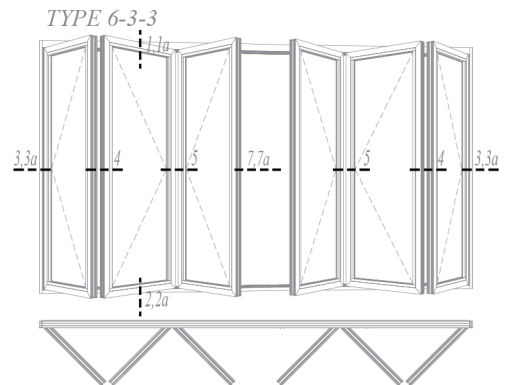
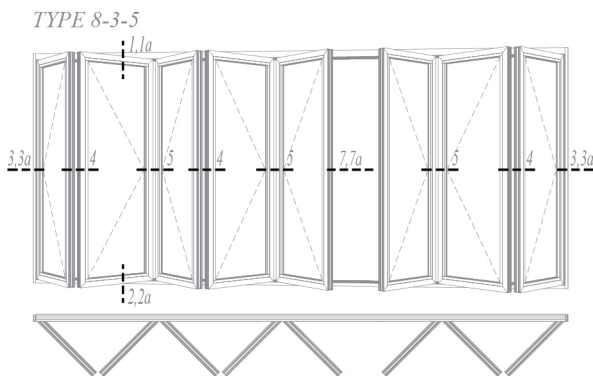
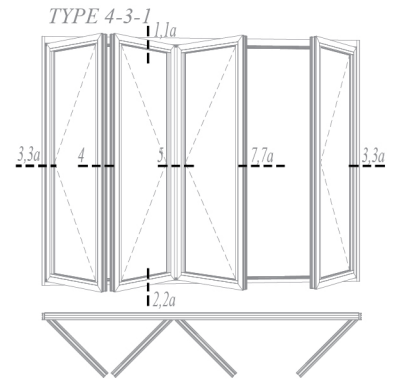
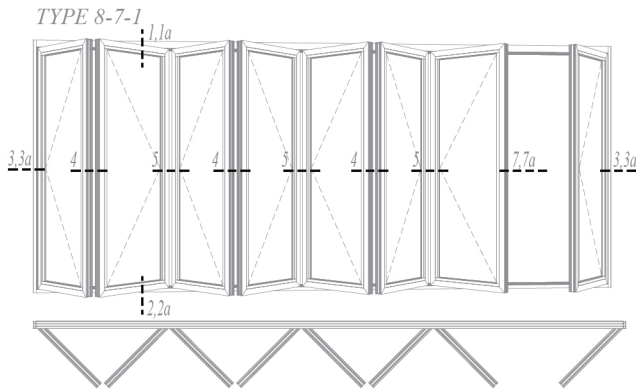
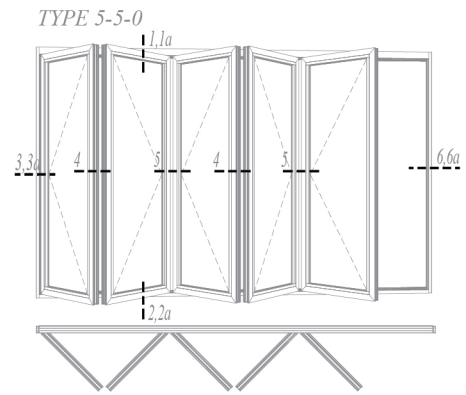
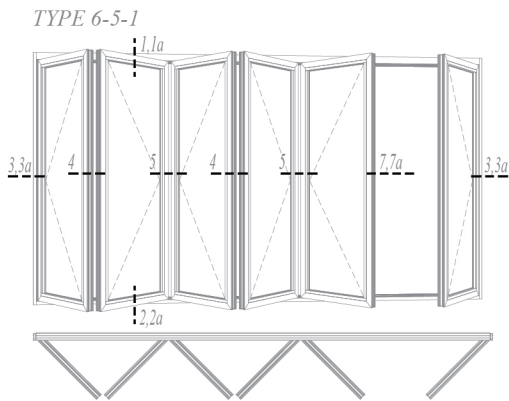
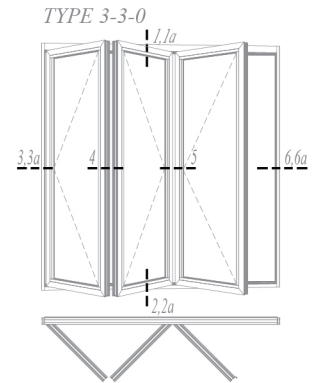
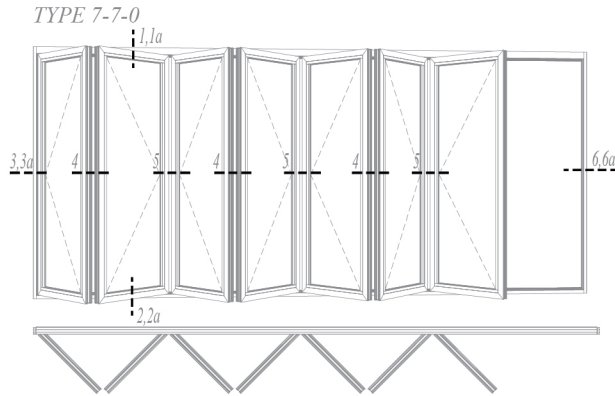

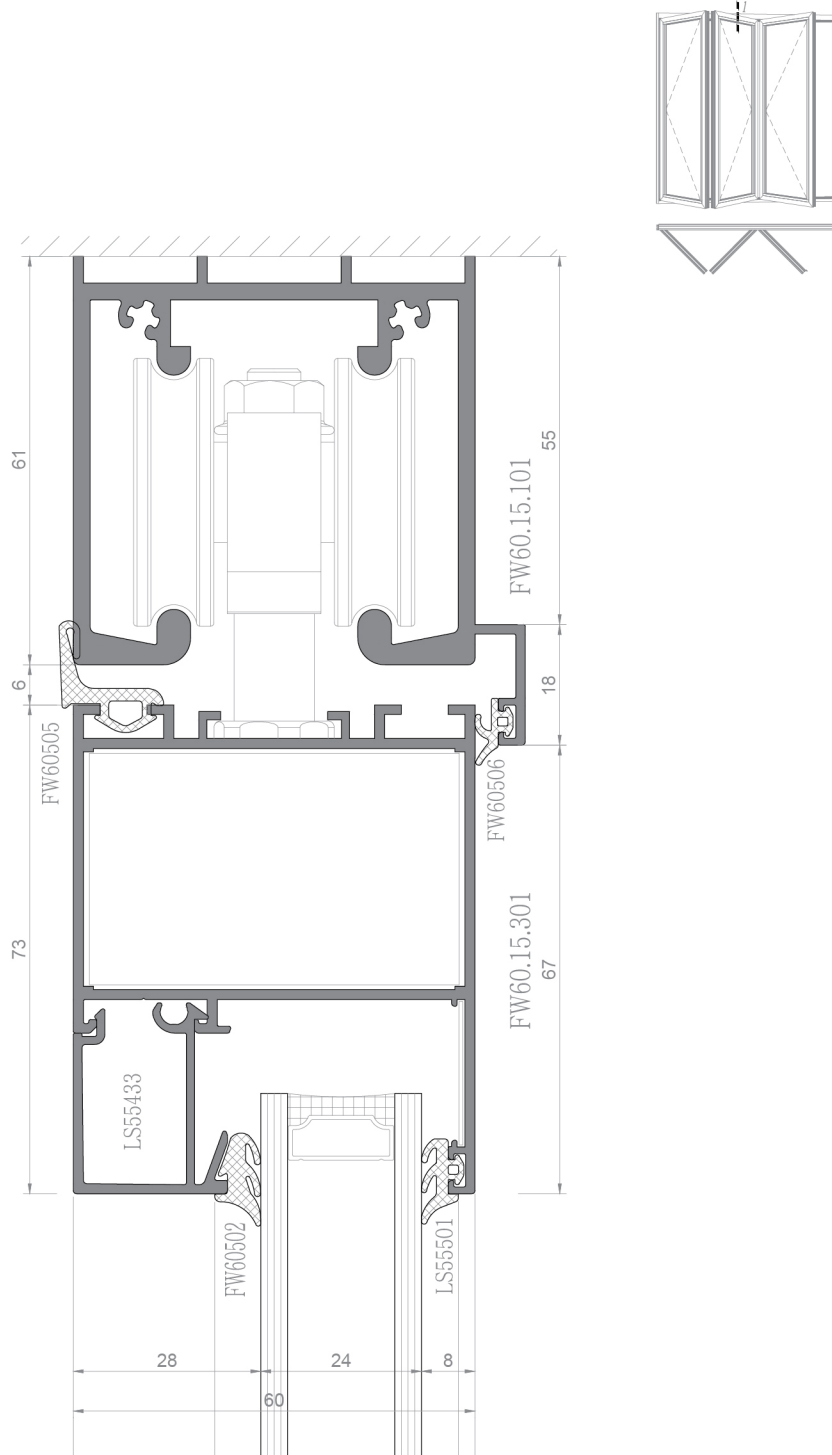

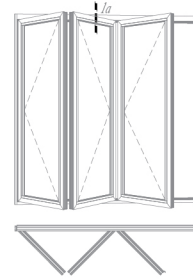
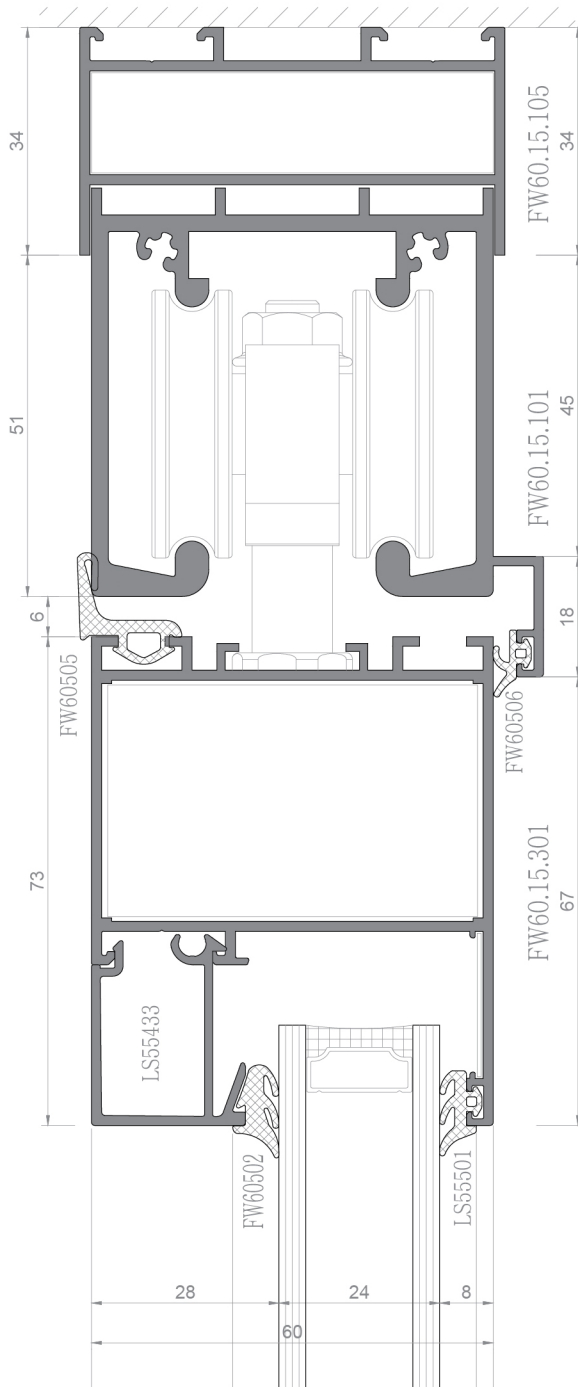

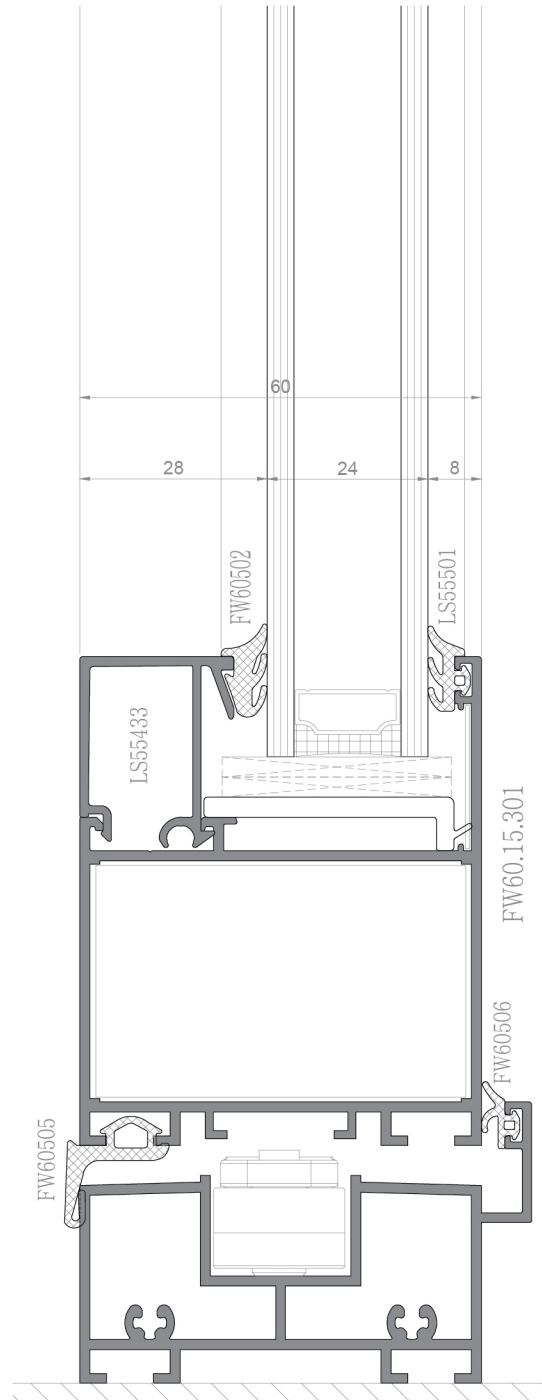
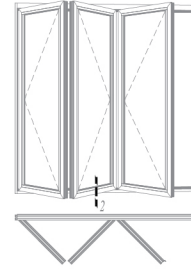

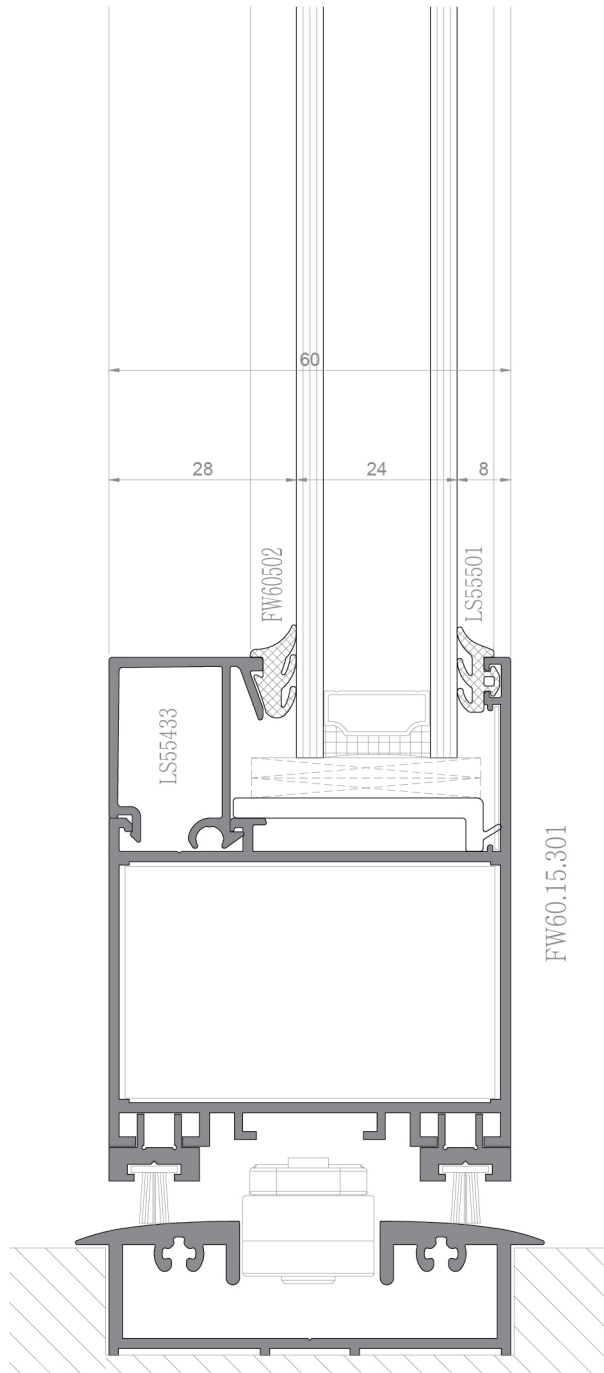
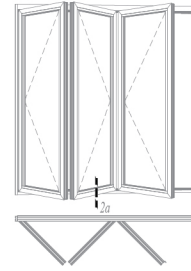

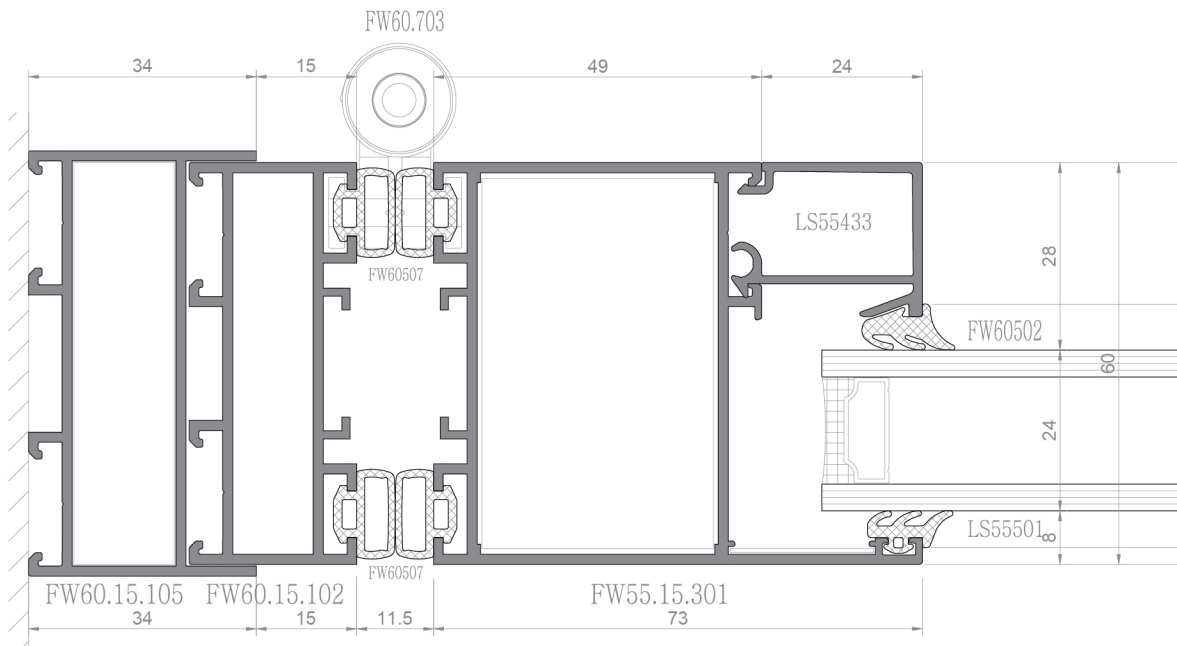
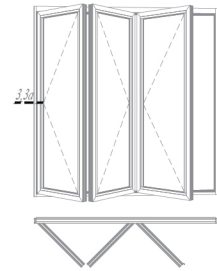
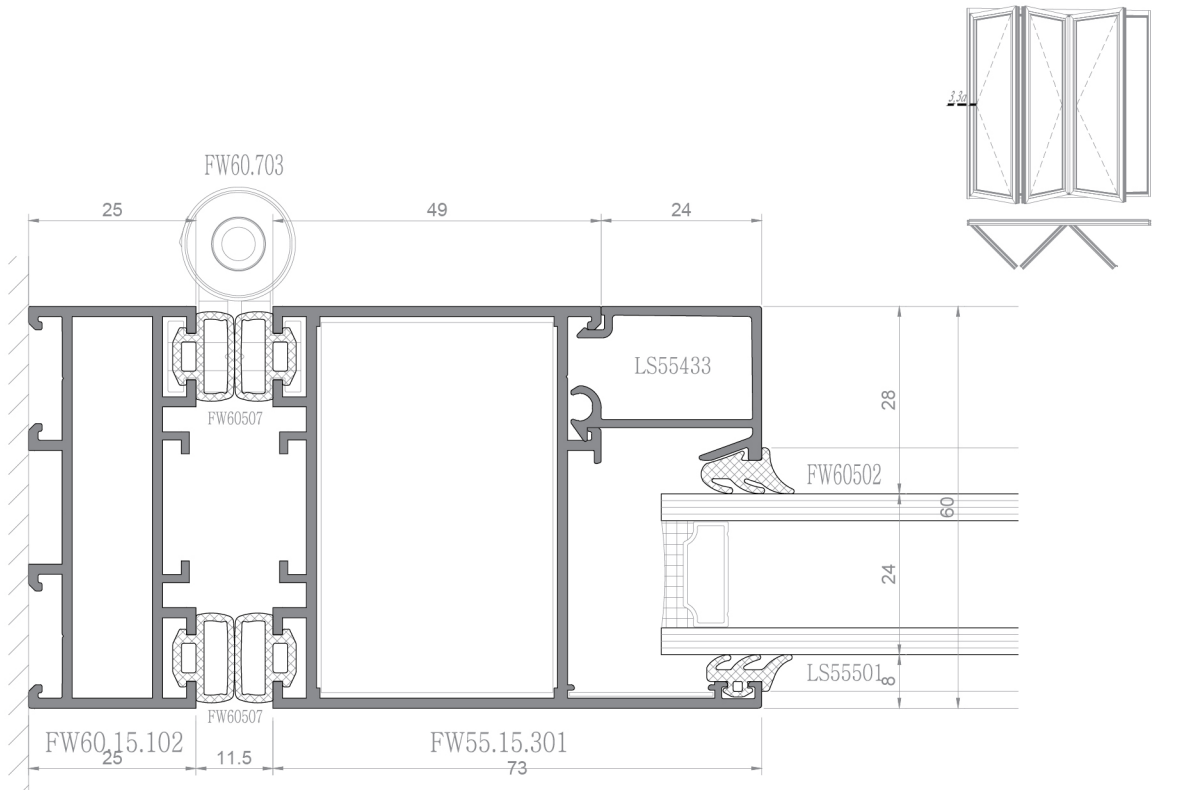

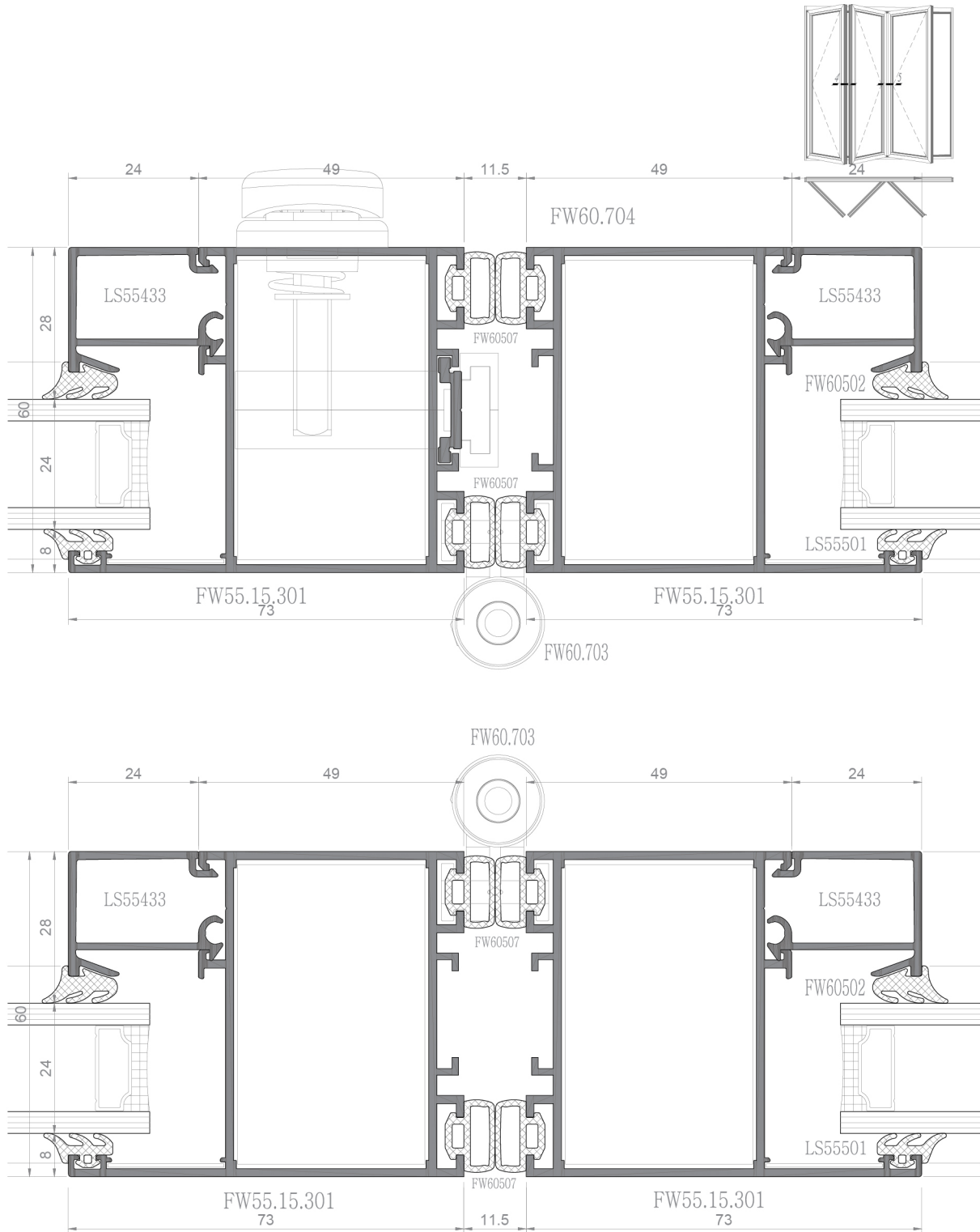

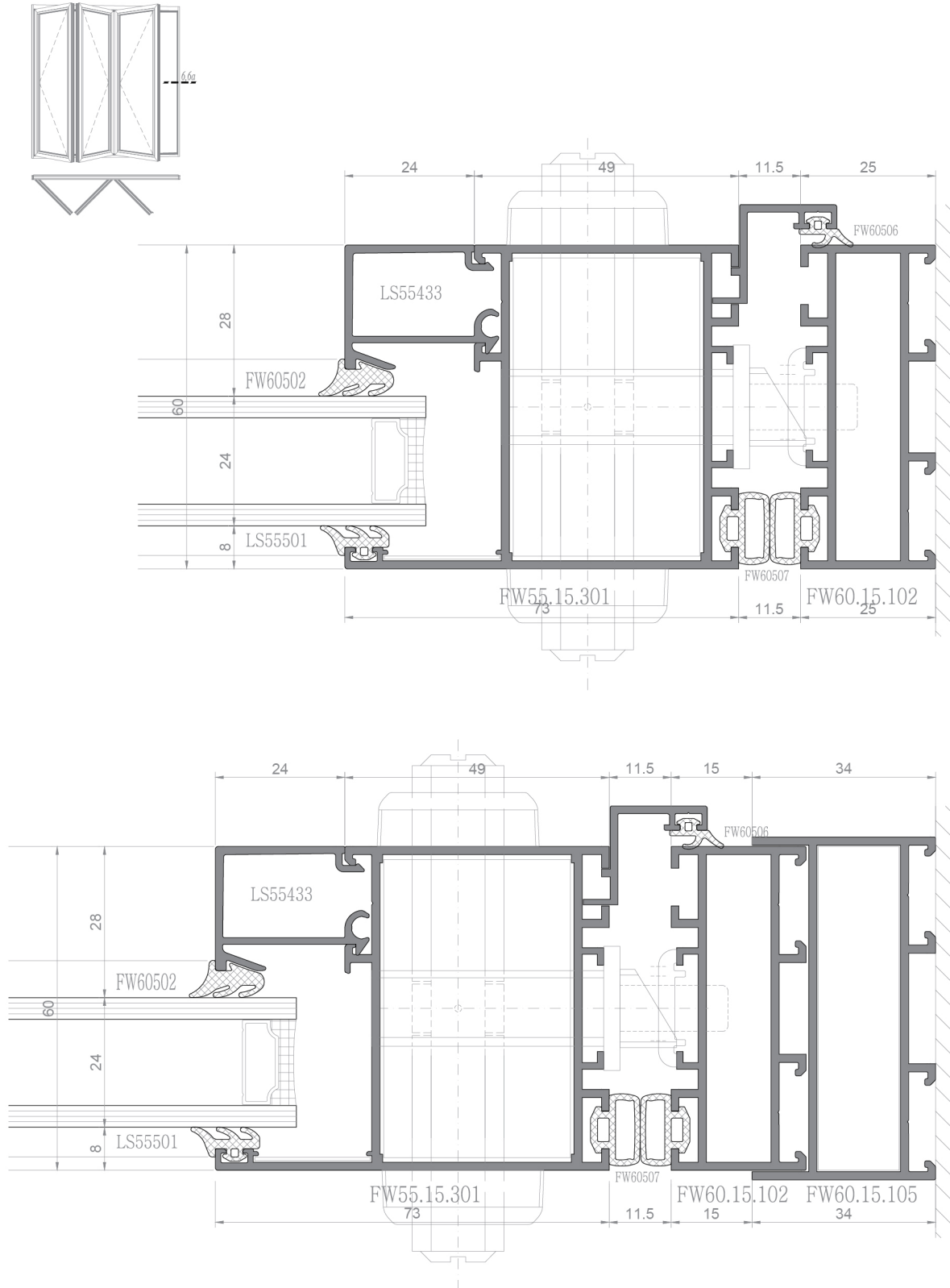

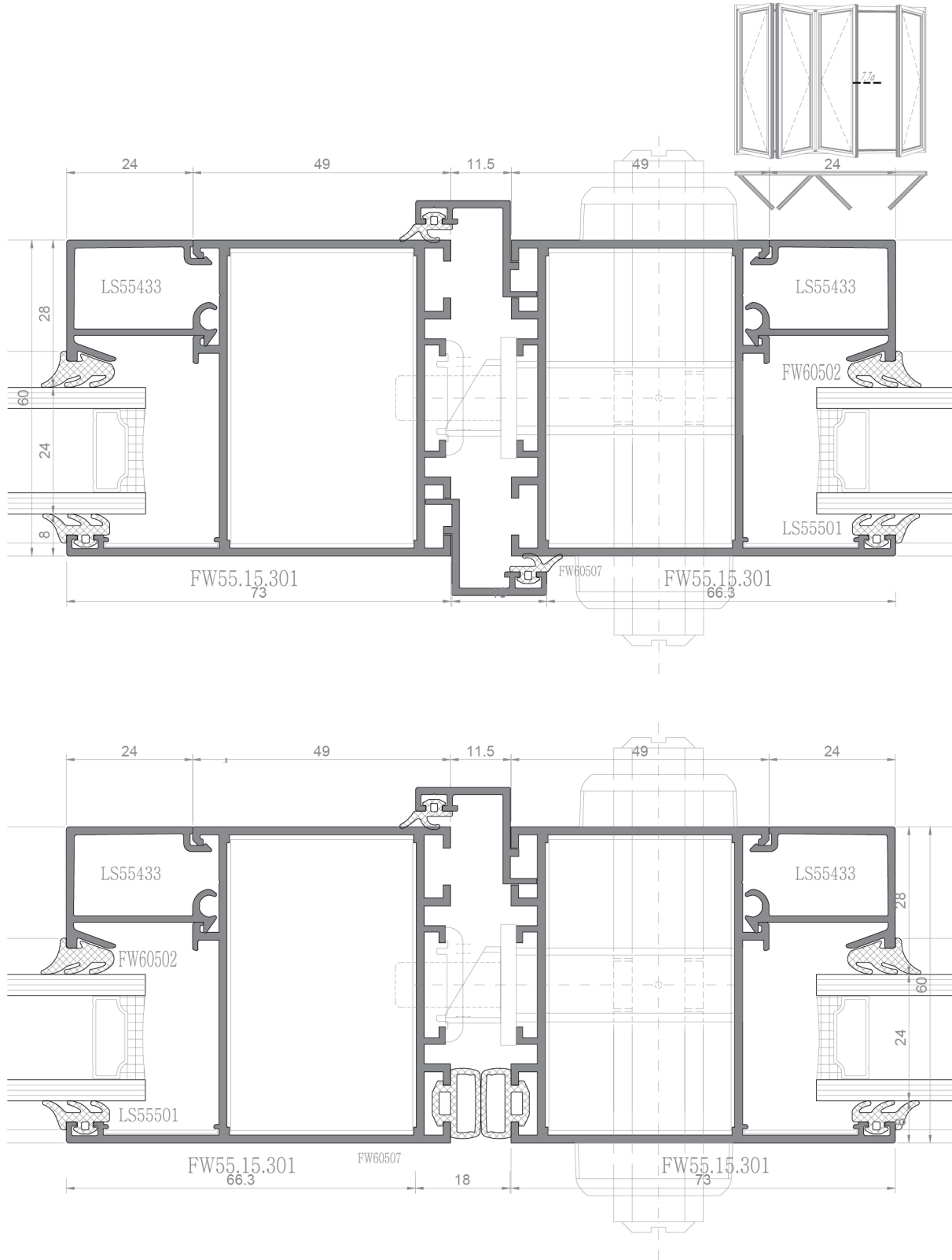

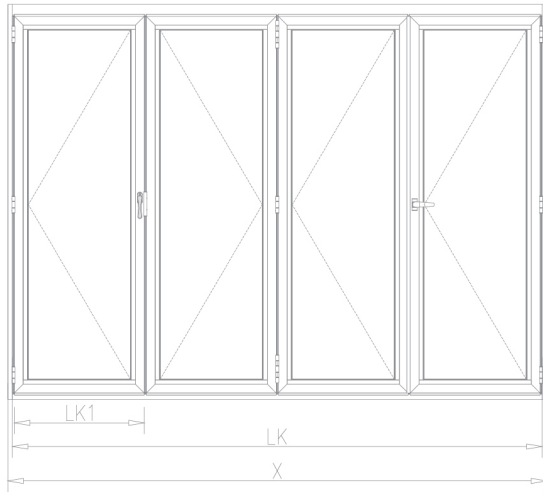
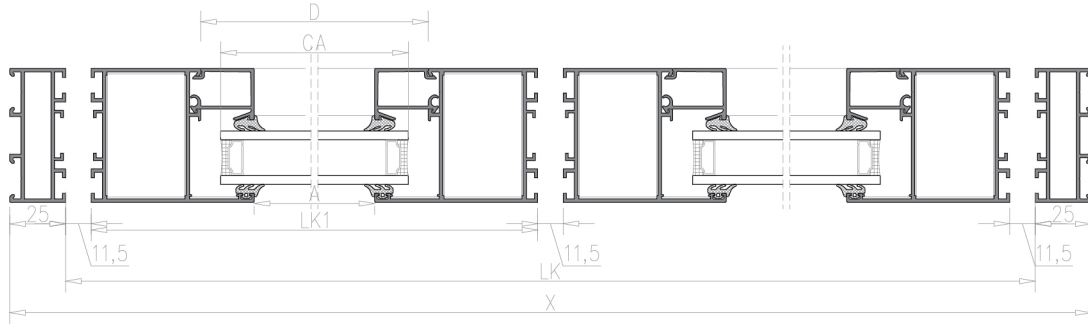

$$LK = X - 50$$

$$LK1 = \frac{LK - 1,5 \times (N + 1)}{N}$$

(number of vent)

$$1$$

$$HK = Y - 81$$

$$HK1 = HK - 17$$

$$2$$

$$HK = Y - 90,5$$

$$HK2 = HK - 12$$

$$D = A + 48$$

$$C = B$$

$$CA = A + 30$$

$$CB = B + 30$$

X	dograma eni
Y	dograma boyu
LK1	kanat yatay ölçüsü
HK1	kanat düşey ölçüsü
LKA	kasa yatay ara ölçü
HKA	kasa düşey ara ölçü
A	kanat yatay ara ölçü
B	kanat düşey ara ölçü
D	çita yatay ölçü
C	çita düşey ölçü
CA	cam yatay ölçüsü
CB	cam düşey ölçüsü

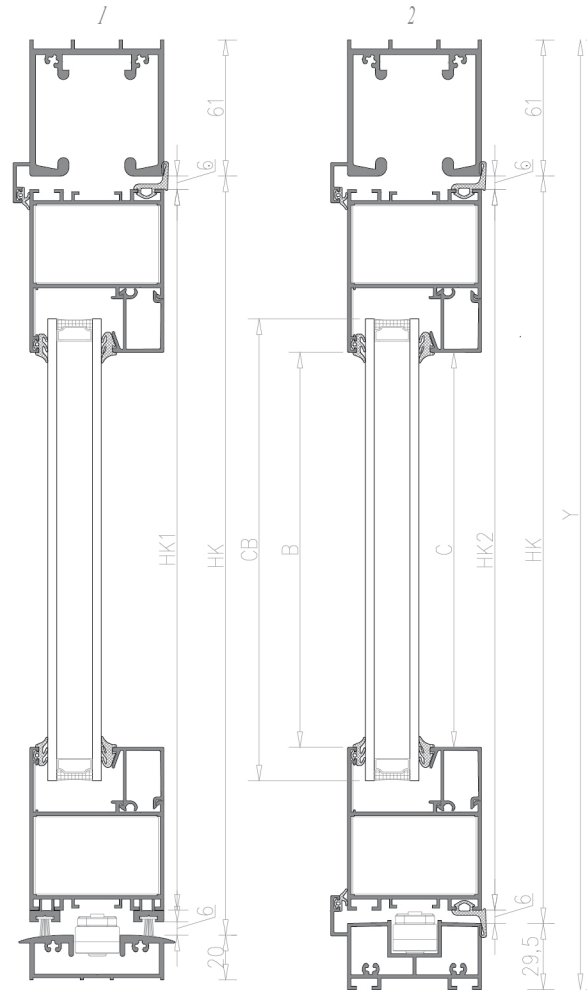

NOT: Son açıklığı ölçtüktan sonra her zaman son kanadı kesiniz.

(always cut the last casement after measuring the last opening.)

