

vetrina

ÖZEL MEKANLAR SİSTEM KATALOĞU

SİLİNEBİLİR GİYOTİN SİSTEM
HAREKETLİ PANEL TAVAN SİSTEM

zahit[®]
ALÜMİNYUM



İSTİKRAR-GÜVEN-KALİTE

STABILITY-TRUST-QUALITY

FİRMA PROFİLİ / COMPANY PROFILE

1983 yılında ilk kapı pencere doğrama atölyesi ile kurulan **Zahit Alüminyum**, Türkiye'nin prestijli bir üretim tesisidir. 90'lı yıllarda şirketleşme süreçleri ile birlikte alt yapı yatırımlarına hız vermiş, üretim noktasında sektörün ilkleri olmayı başarmış bir firmadır. 1998 yılında ekstrüzyon prosesi ile ilk profilleri üretmiş ve 2000'li yılların başında üretim kapasitesini artırmak ve daha kaliteli ürünler üretmek için yeni üretim hatları ve yüzey işlem hatlarını devreye almıştır. Şu an beş binin üzerinde olan ürün çeşitliliği ile Enerji, İnşaat, Otomotiv, Savunma Sanayi, Elektrik-Elektronik, Medikal, Mobilya ve Reklam Sektörlerinde faaliyet göstermektedir.

Adana Organize Sanayi bölgesinde, 40.000 m² kapalı olmak üzere toplam 60.000m² alanda, yıllık 25.000 ton biyet döküm, 20.000 ton 6 adet) kapasiteli alüminyum ekstrüzyon profil hattı, 1.500.000m² kapasiteli B-1/B-2/A2 alüminyum kompozit panel tesisi, 7.500 ton üretim kapasiteli dikey elektrostatik boyama hattı, 700 ton kapasiteli ahşap kaplama hattı, 12.000 ton kapasiteli eloksal yüzey kaplama hattına sahiptir. Entegre yönetim sistemi ile uluslararası kalite standartlarında üretim yapmakta, istikrarlı satış politikası ile müşteri taleplerine hızlı ve ekonomik çözümler sunmaktadır. **Zahit Alüminyum**, ISO 9001, ISO 14001, ISO 45001, ISO 27001, ISO 50001 ve AFGM Onaylı Tedarikçi yönetim sistemlerine sahiptir. TSE, CE, ROHS, REACH, QUALANOD ve QUALICOAT Seaside sertifikalarına sahip ürünler üretmektedir. Her yıl bünyesi içerisinde 5S tekniklerini uygulamakta ve proses iyileştirmeleri ile maliyet düşüşleri sağlamaktadır. Ayrıca üretmiş olduğu ürünler ile "Teknolojik Ürün (TÜR) Deneyim Belgesi" almaya hak kazanmıştır.

Ar-Ge Merkezi, dökümhane, kalıphane, ekstrüzyon pres hattı, eloksal yüzey işlem tesisi, elektrostatik toz boya tesisi, ahşap kaplama tesisi, mekanik işlem birimi, alüminyum kompozit panel üretim hattı ve kalite kontrol birimlerinin birbiri ile entegre çalışması Zahit Alüminyum'u sektörde herkesin bildiği ve güvendiği firma profili seviyesine getirmiştir. **Alüminance** ve **Vetrina** markaları ile alüminyum profil grubunda mimari sistem profilleri, endüstriyel profiller, solar konstrüksiyon, kompozit paneller, A2 yanmaz kompozit panellerin üretimlerini gerçekleştirmektedir.



Founded in 1983 with the first door and window joinery workshop, **Zahit Aluminum** is a prestigious production facility in Turkey. It is a company that has accelerated its infrastructure investments with the incorporation processes in the 90s and succeeded in being the first of the sector in terms of production. It produced the first profiles with the extrusion process in 1998 and commissioned new production lines and surface treatment lines in order to increase its production capacity and produce higher quality products in the early 2000s. It currently operates in the Energy, Construction, Automotive, Defense Industry, Electric-Electronics, Medical, Furniture and Advertising Sectors with its product range of more than five thousand.

In Adana Organized Industrial Zone, in 60.000m² open and 40.000m² closed area, annual 25.000 tons of billet casting, 20.000 tons (6 pieces) aluminum extrusion profile line, 1.500.000m² capacity B-1/B-2/A2 aluminum composite panel plant, It has a vertical electrostatic painting line with a production capacity of 7,500 tons, a wood coating line with a capacity of 700 tons, an anodized surface coating line with a capacity of 12,000 tons. It manufactures at international quality standards with its integrated management system, and offers fast and economical solutions to customer demands with its stable sales policy. **Zahit Aluminum** has ISO 9001, ISO 14001, ISO 45001, ISO 27001, ISO 50001 and AFGM Approved Supplier management systems. It produces products with TSE, CE, ROHS, REACH, QUALANOD and QUALICOAT Seaside certificates. Every year, it applies 5S techniques within its body and provides cost reductions with process improvements. In addition, it has been entitled to receive a "Technological Product (TUR) Experience Certificate" with the products it has produced.

The integrated work of the R&D Center, foundry, molding room, extrusion press line, anodized surface treatment facility, electrostatic powder paint facility, wood coating facility, mechanical processing unit, aluminum composite panel production line and quality control units make Zahit Aluminum everyone in the sector. brought him to the level of the company profile he knows and trusts. It produces architectural system profiles, industrial profiles, solar construction, composite panels, A2 fireproof composite panels in the aluminum profile group with the brands of **Alüminance** and **Vetrina**.

vetrina

Silinebilir Giyotin Sistem

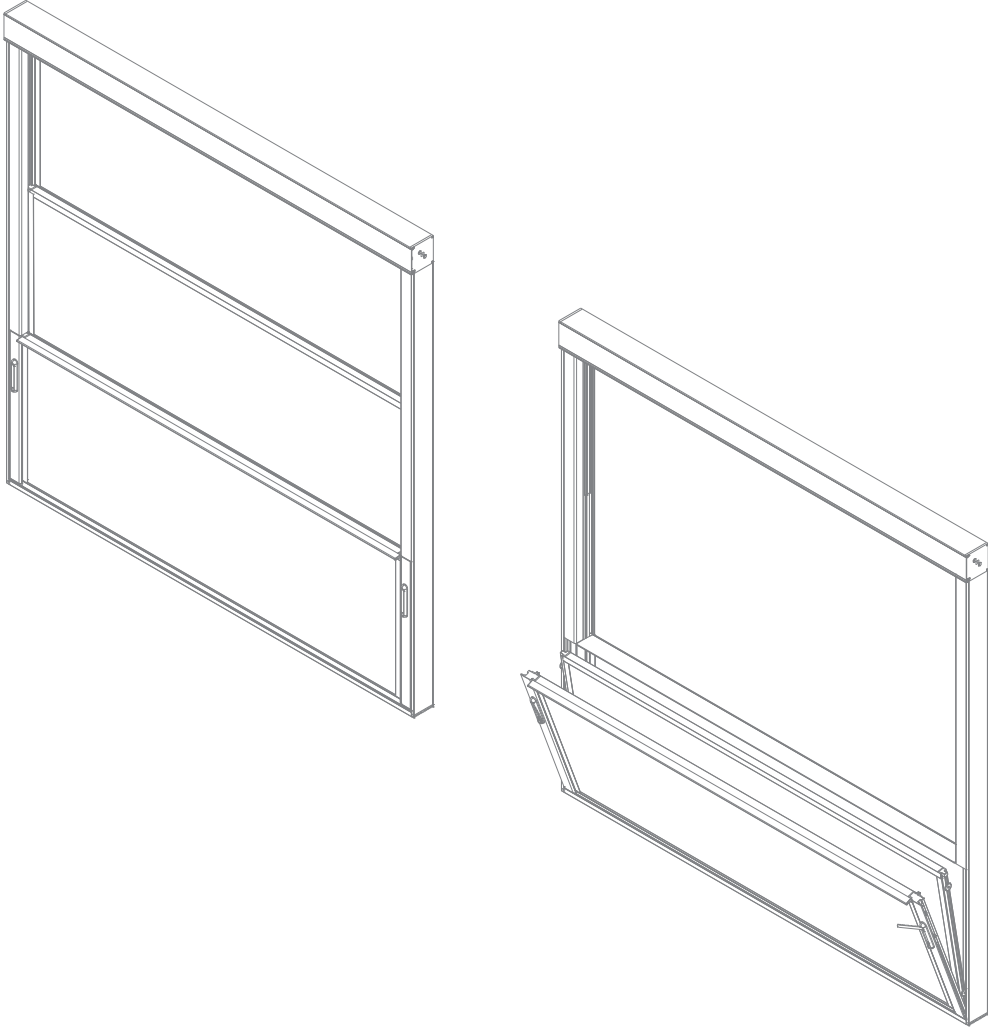

SİLİNEBİLİR GİYOTİN SİSTEM	SİLİNEBİLİR GİYOTİN SİSTEM	V.GY.	V.GY.	201
	<ul style="list-style-type: none">▼ Zincirli ve Kayışlı Mekanizma Alternatifi▼ Cam Özelliği; 8 mm, 10 mm ve 4 mm+12Hb+4 mm▼ Max. En : 350 cm / Boy: 300 cm		SİSTEM	PR NO



İÇİNDEKİLER

Silinebilir Giyotin Sistem

Silinebilir Giyotin Sistem Profilleri	05-07
Silinebilir Giyotin Sistem Aksesuarları	08-10
Silinebilir Giyotin Sistem Montaj Çizimleri	11-17
Silinebilir Giyotin Sistem Kesim Çizimleri	18-23

Hareketli Panel Tavan Sistem

Hareketli Panel Tavan Sistem Profilleri	25-26
Hareketli Panel Tavan Sistem Aksesuarları	27-29
Hareketli Panel Tavan Sistem Montaj Çizimleri	30-33

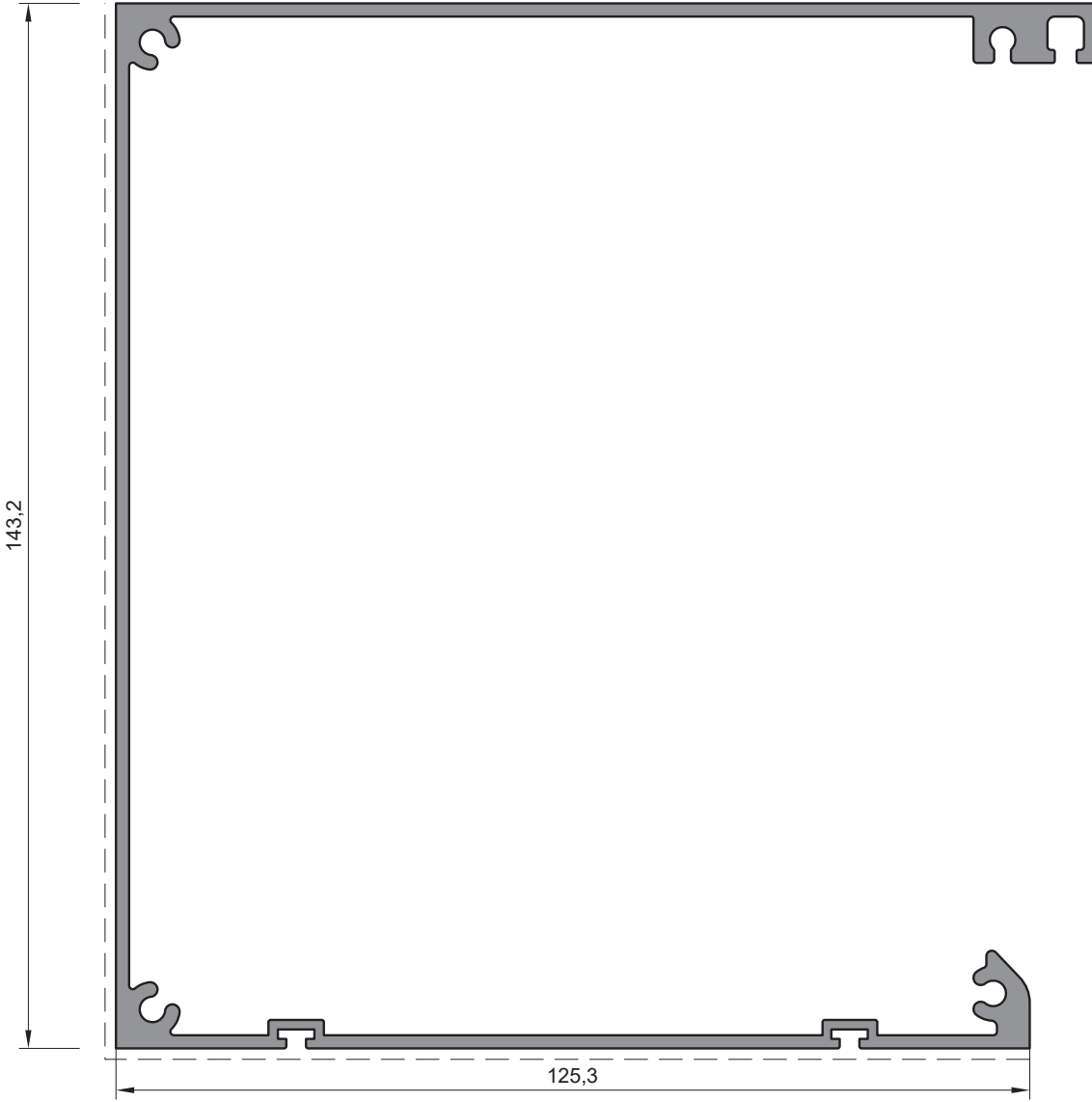

MOTOR KAPAK PROFİLİ
V.GY.104
2.452 kg/mt

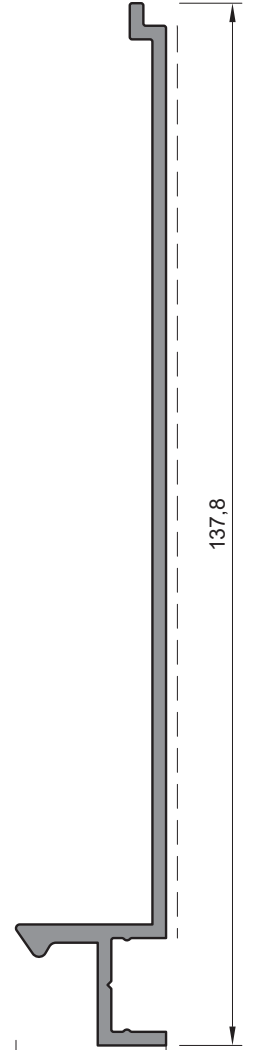

MOTOR KAPAK
KAPATMA PROFİLİ
V.GY.105
0.837 kg/mt

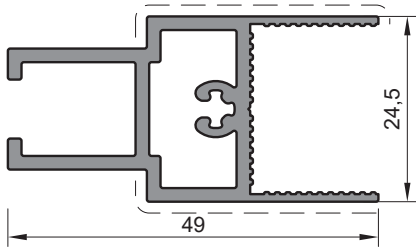

DİKEY BAZA PROFİLİ
V.GY.103
0.706 kg/mt

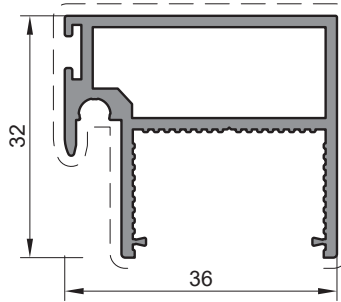

KENET PROFİLİ
V.ES.109
0.606 kg/mt

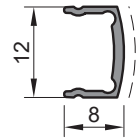

MOTOR KAPAK PROFİLİ
2458
0.065 kg/mt

* Belirtilen ağırlıklar pres profil için teorik kilogramlardır. * Boyalı profillerde ağırlığa % 5 ilave edilmelidir.

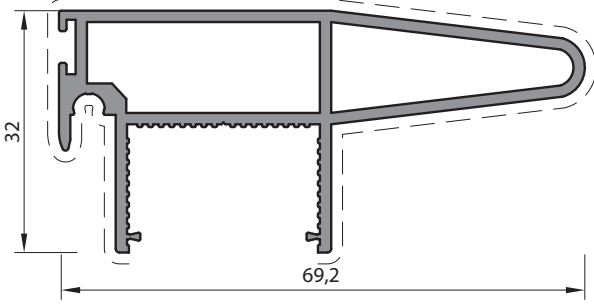

TUTAMAKLI BAZA PROFİLİ
V.GY.206
0.890 kg/mt

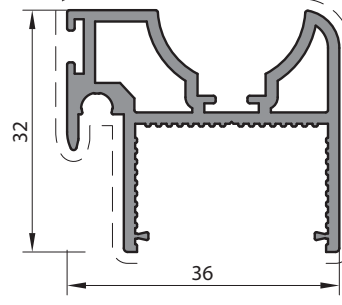

ORTA ALT BAZA PROFİLİ
V.GY.209
0.655 kg/mt

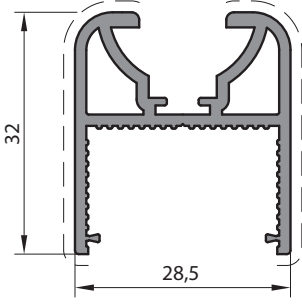

KÜPEŞTE BAZA PROFİLİ
V.GY.207
0.575 kg/mt

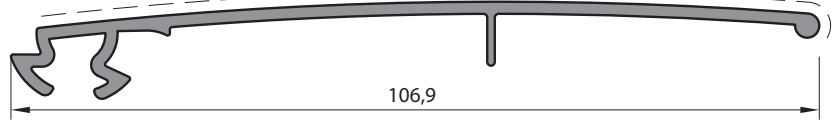

HAREKETLİ KÜPEŞTE PROFİLİ
V.GY.208
0.573 kg/mt

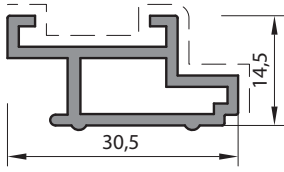

VASİSTAS KASA PROFİLİ
V.GY.204
0.342 kg/mt

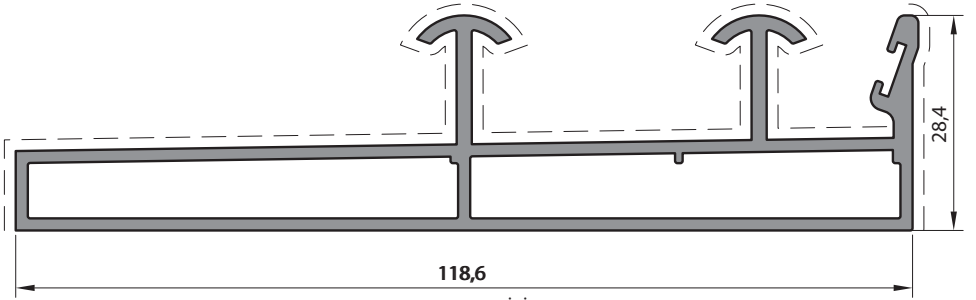

ALT KASA PROFİLİ
V.GY.205
1.561 kg/mt

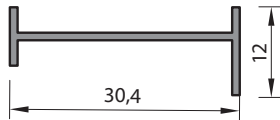

KENET DESTEK PROFİLİ
V.ES.112
0.130 kg/mt

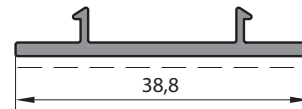

YAN KAPAMA PROFİLİ
V.GY.110
0.217 kg/mt

* Belirtilen ağırlıklar pres profil için teorik kilogramlardır. * Boyalı profillerde ağırlığa % 5 ilave edilmelidir.

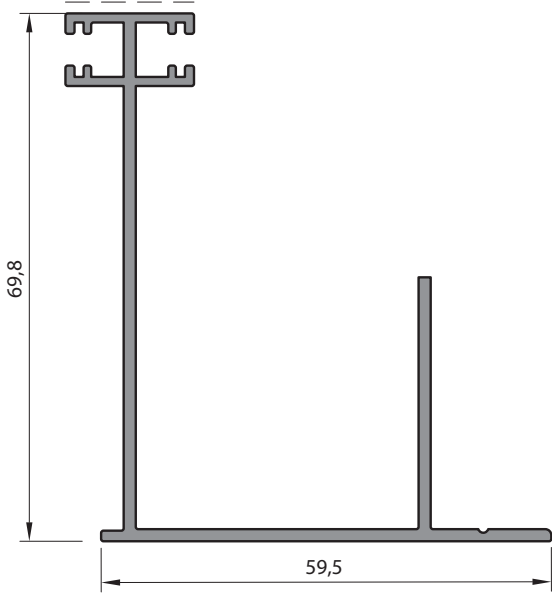

KENET DESTEK PROFİLİ

V.GY.201
0.830 kg/mt

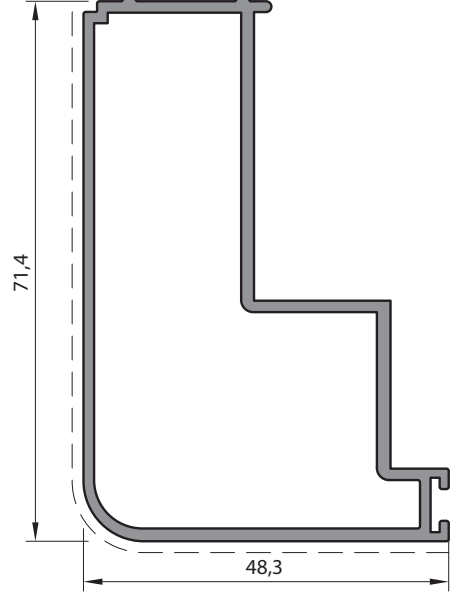

KANAT TAMAMLAYICI PROFİLİ

V.GY.202
0.993 kg/mt

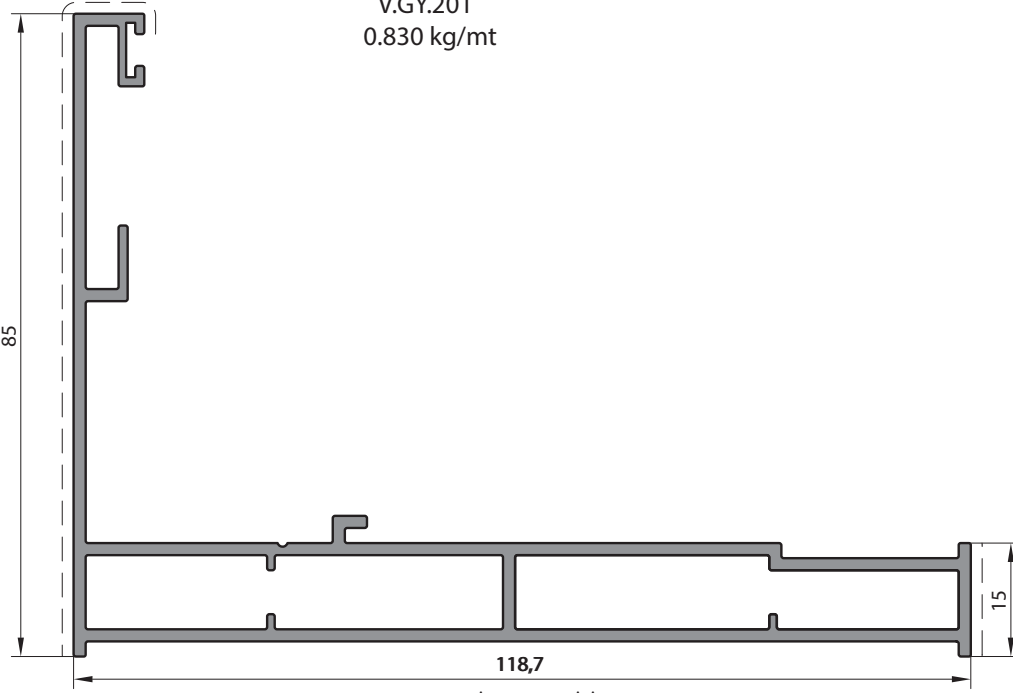

ANA DİKME PROFİLİ

V.GY.101
1.650 kg/mt

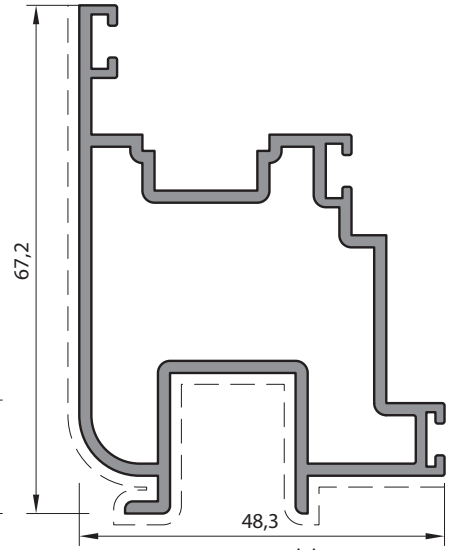

KANAT PROFİLİ

V.GY.203
1.122 kg/mt

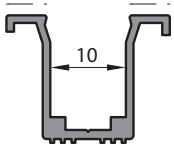

V.ES.103
0.174 kg/mt

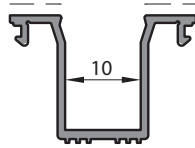

V.ES.104
0.176 kg/mt

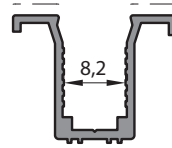

V.ES.116
0.169 kg/mt

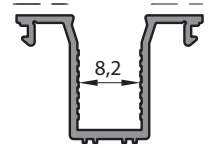









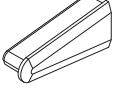
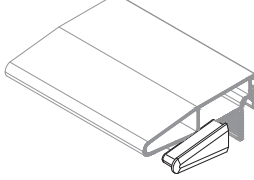
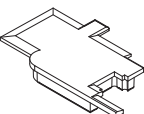
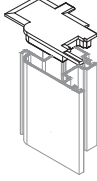
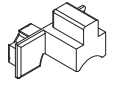
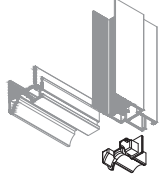
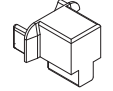
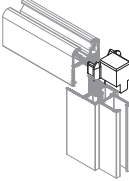
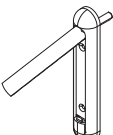
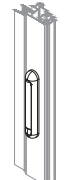

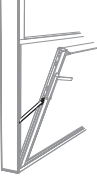

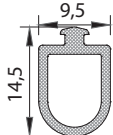
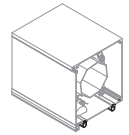
V.ES.115
0.178 kg/mt

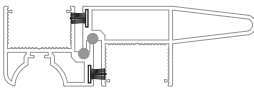
TEK CAM ÇİTA PROFİLLERİ

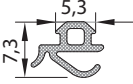
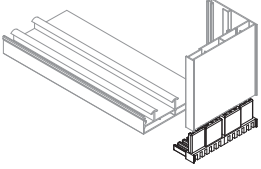
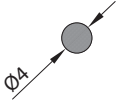
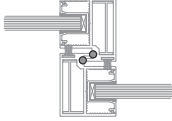
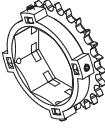
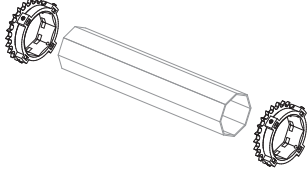
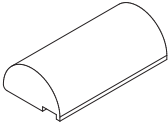
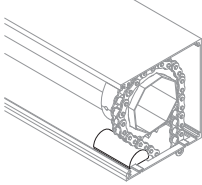
* Belirtilen ağırlıklar pres profil için teorik kilogramlardır. * Boyalı profillerde ağırlığa % 5 ilave edilmelidir.

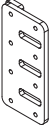
KOD	ŞEKİL	TANIM	PAKET METRAJİ	KULLANIM YERİ
AKS-GY 01		Kasa Köşe Birleştirme Takoğu (PVC)	2	
AKS-GY 02		Motor Tarafı Kapak (PVC)	1	
AKS-GY 03		Boru Başı Kapak (PVC)	1	
AKS-GY 04		Rulman Yatağı	1	
AKS-GY 05		Boru Başı Alüminyum	1	
AKS-GY 07		Merkekleme Takoğu (PVC)	8	
AKS-GY 08		Kenetli Baza Kapak (PVC)	2L+2R	
AKS-GY 19		Vasistas Alt Takoğu (PVC)	1L+1R	
AKS-GY 20		Vasistas Alt Kasa Takoğu	1L+1R	

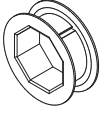
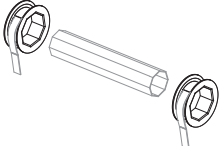
KOD	ŞEKİL	TANIM	PAKET METRAJİ	KULLANIM YERİ
AKS-GY 21		Tutamaklı Baza Kapak	2	
AKS-GY 22		Vasistas Üst Kapak	1L+1R	
AKS-GY 23		Orta Vasistas Alt Kasa Takoz	1L+1R	
AKS-GY 24		Küpeşte Takoz	2	
AKS-GY 25		Vasistas Kol	2	
AKS-GY 26		Vasistas Makas	2	
AKS-GY 27		İspanyolet kilit	2	
Z-94		Epdm Kapak Baskı Fitolu	65 gr/m 153 m	
LS55520		Fırça Fitolu	400 m/pk	

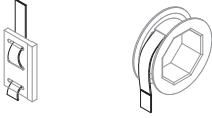
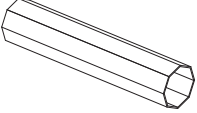
KOD	ŞEKİL	TANIM	PAKET METRAJİ	KULLANIM YERİ
Z-63		Epdm Kanat Baskı Fiteli	40 gr/m 200 m	
W55.511		Epdm Kenet Fiteli	16 gr/m 609 m	
AKS-GY 11		Zincir Dişlisi	2	
AKS-GY 13		Zincir Yönlendirici	2	
AKS-GY 14		Zincir 2,5 m	2	
AKS-GY 15		Zincir ve Kayış Tutucu	2	
AKS-GY 16		Kayış Kasnağı	2	
AKS-GY 17		Kayış 2,5 m	2	
AKS-GY 18		Motor Borusu	1	

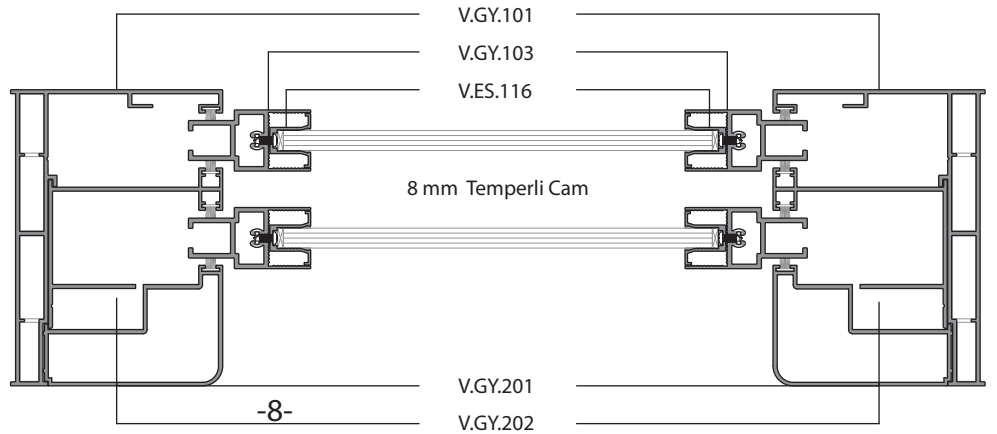
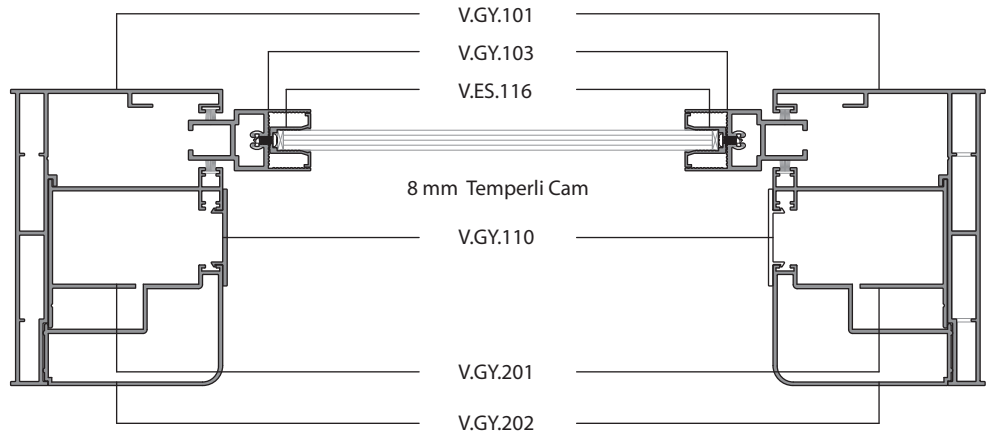
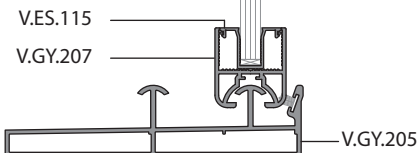
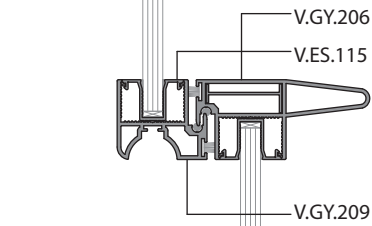
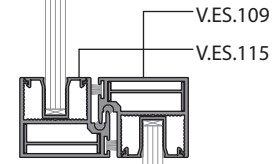
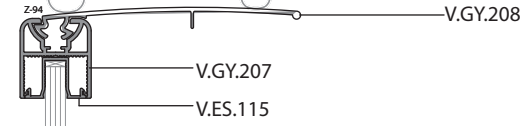
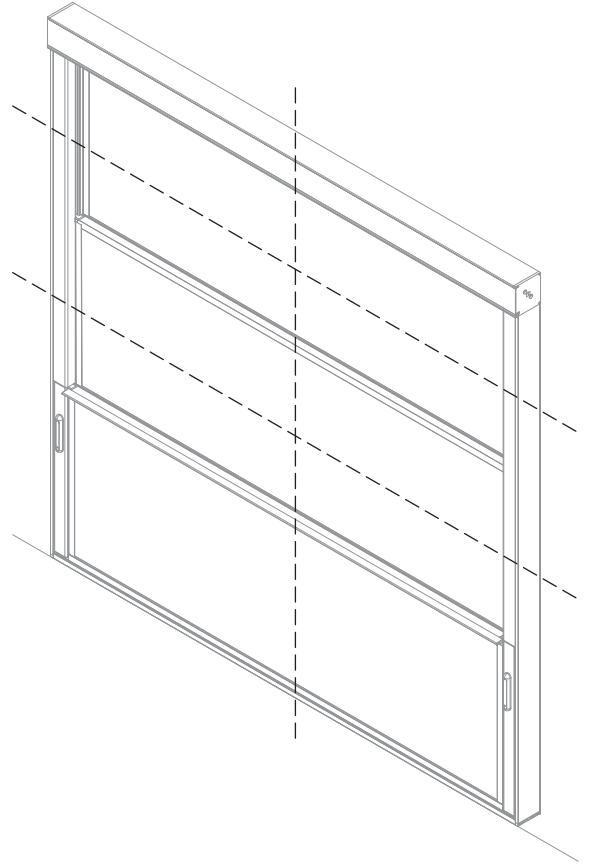
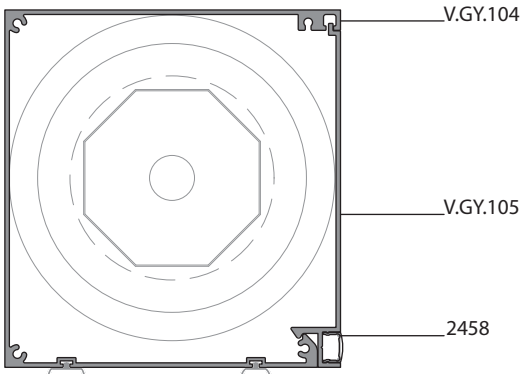

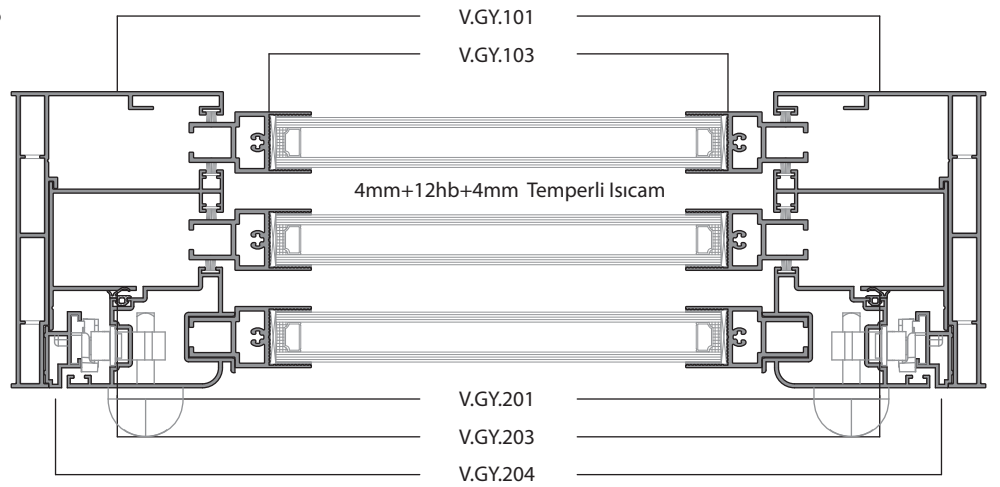
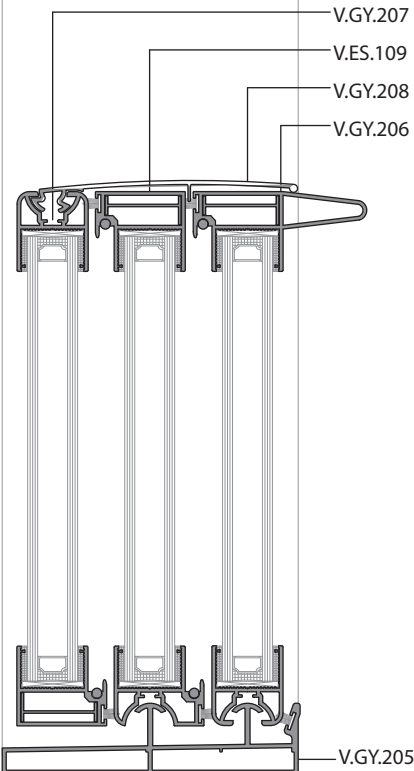
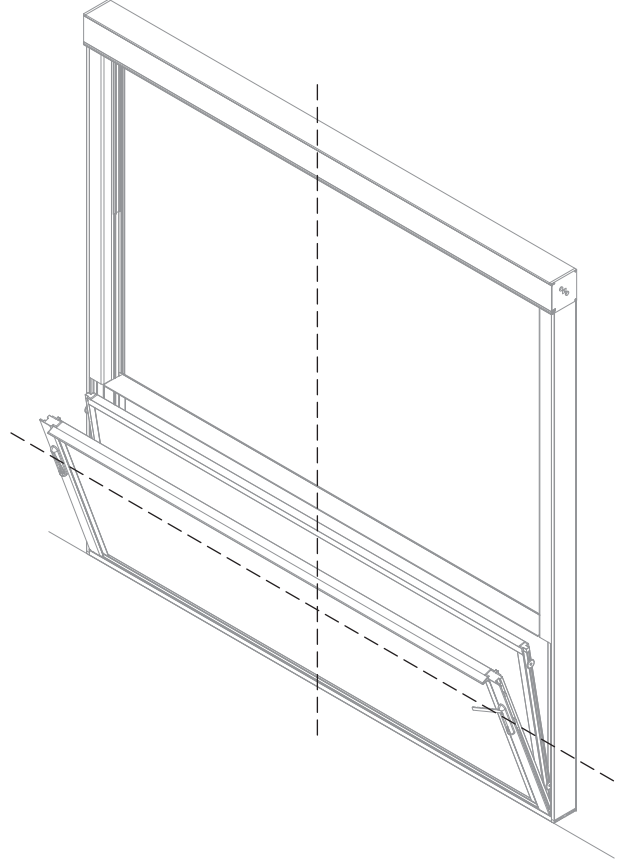
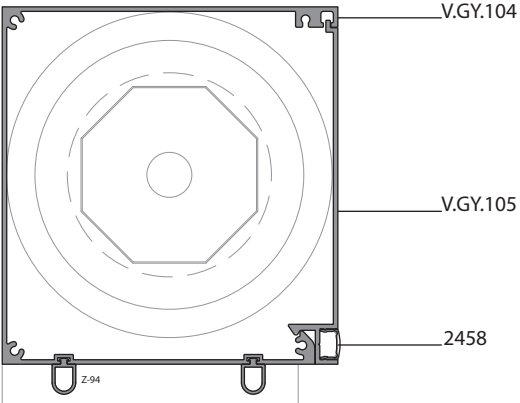

AÇILIR PANEL MONTAJ

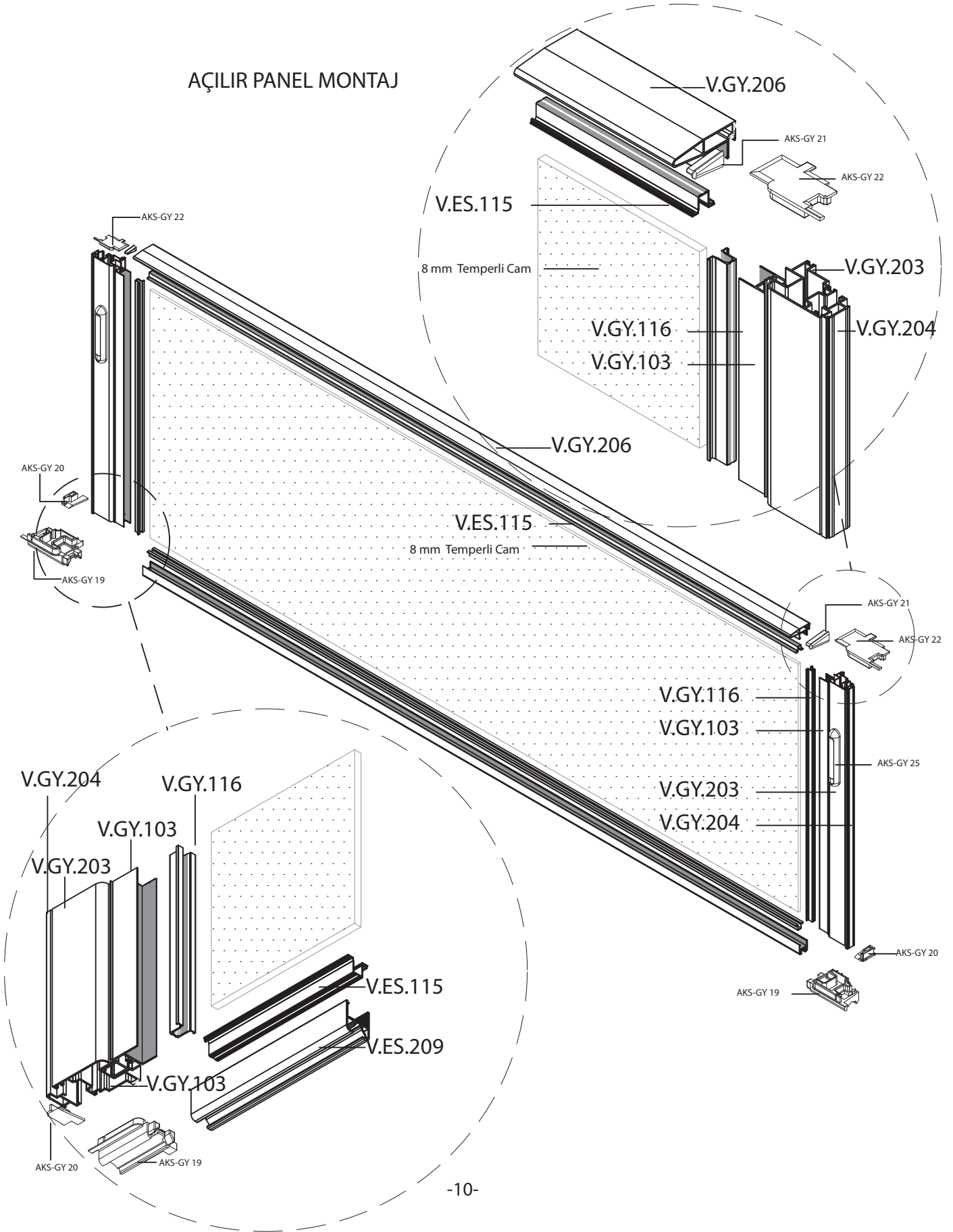

ORTA PANEL MONTAJ

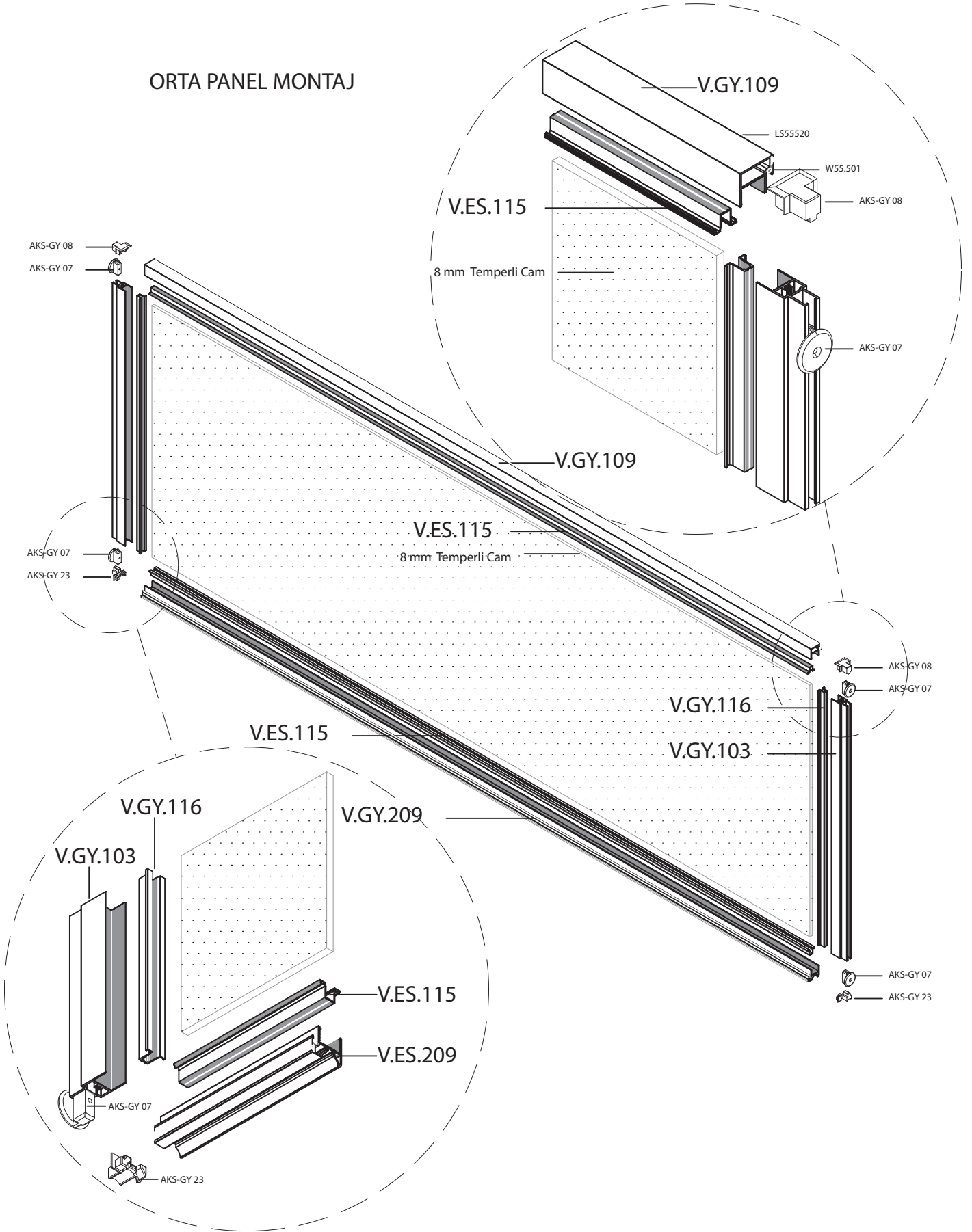

DIŞ PANEL MONTAJ

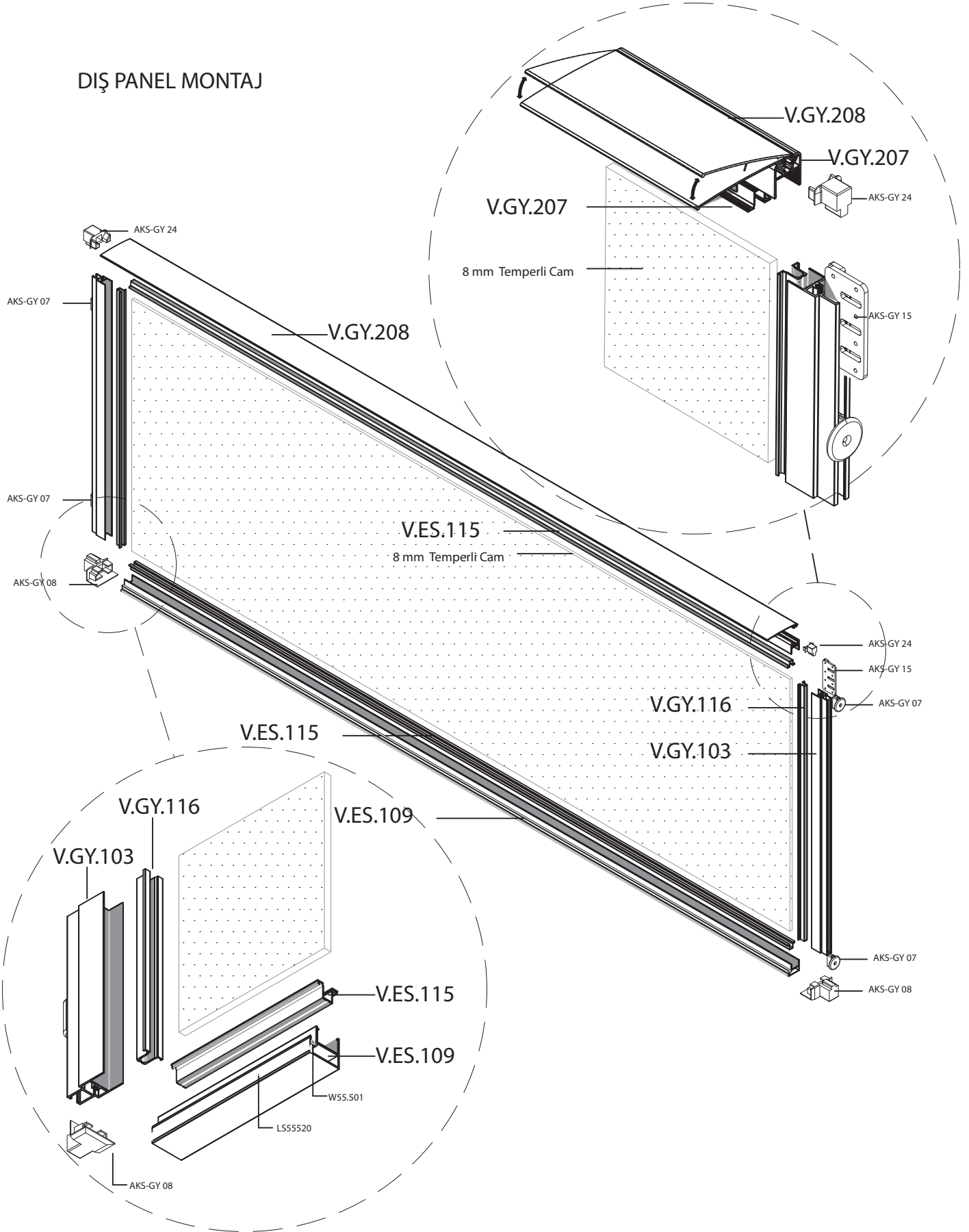

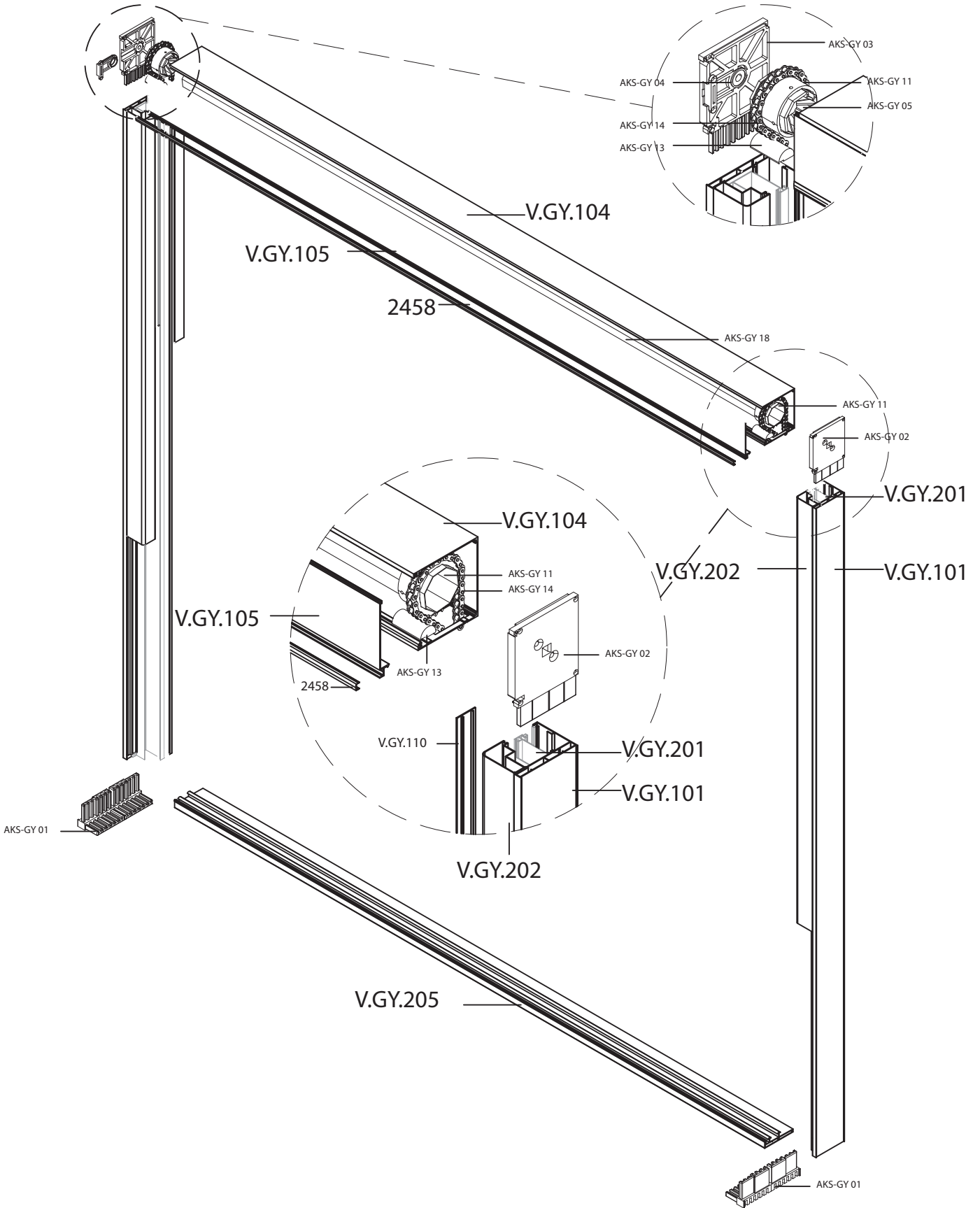

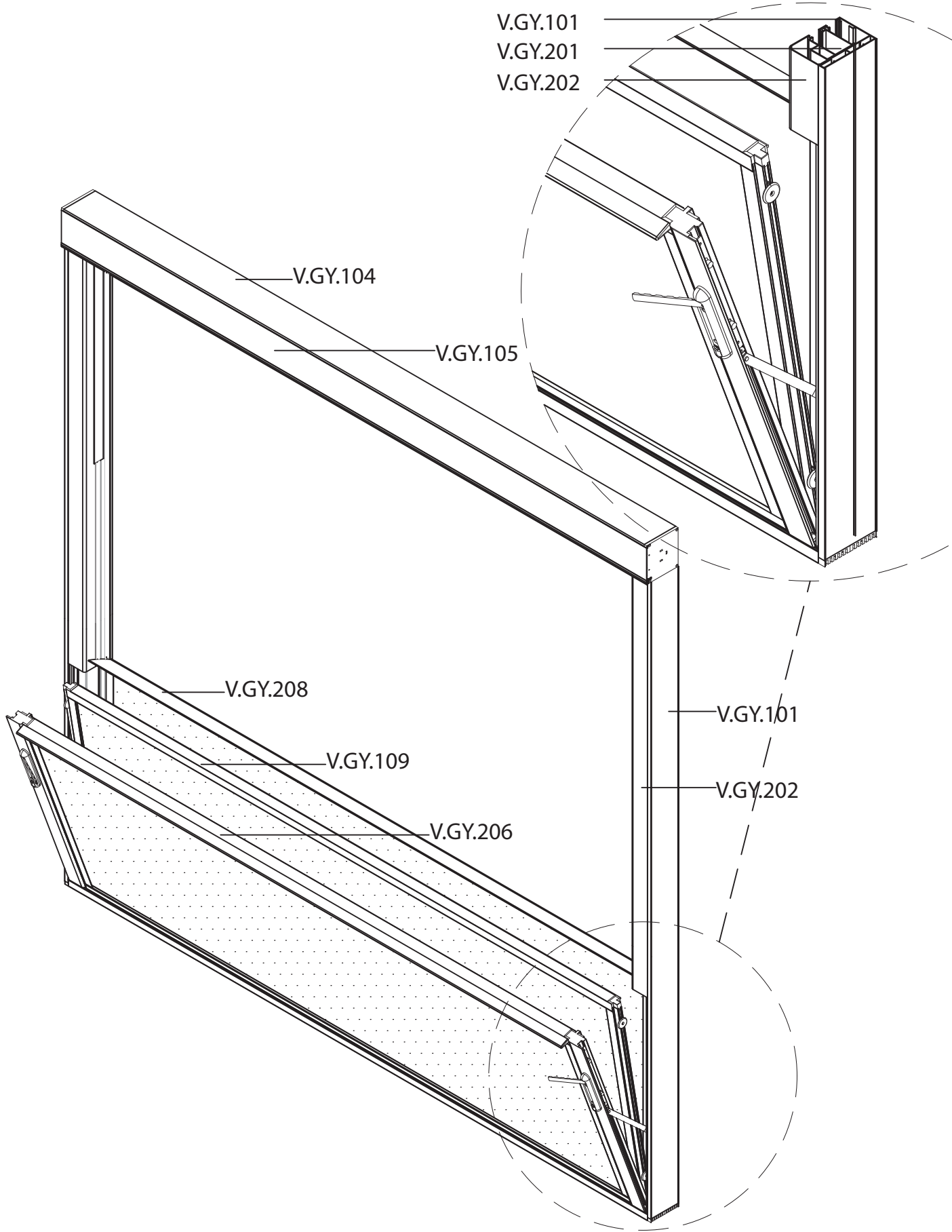

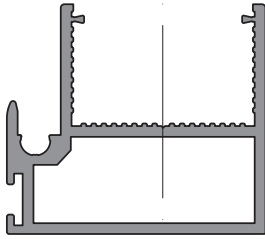
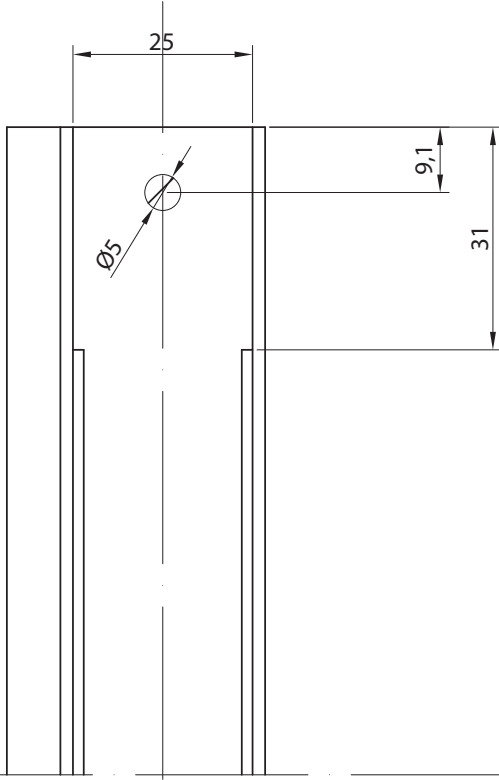

V.ES.109

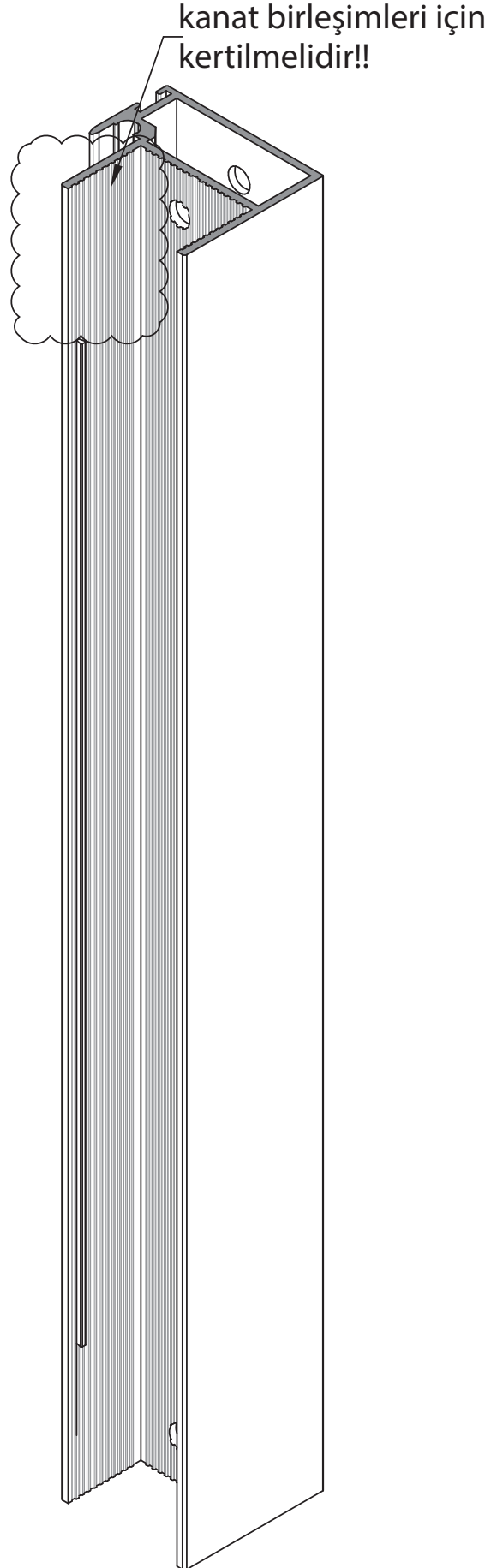
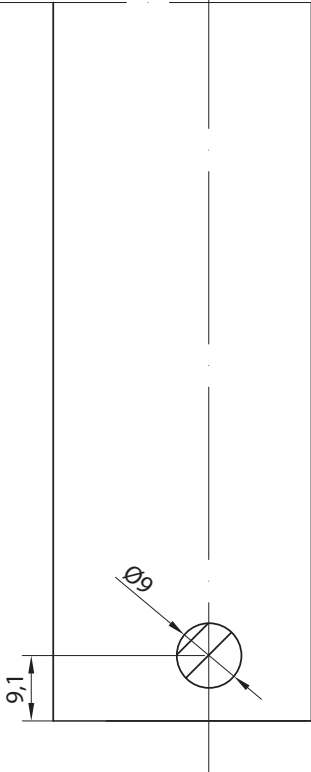

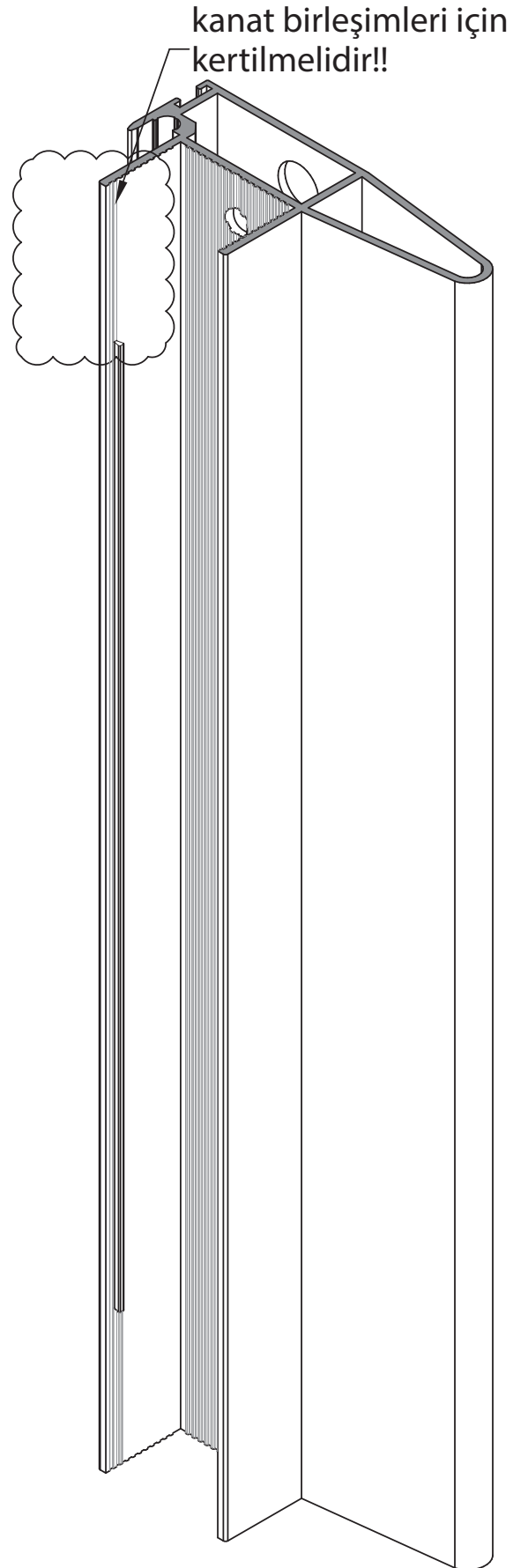
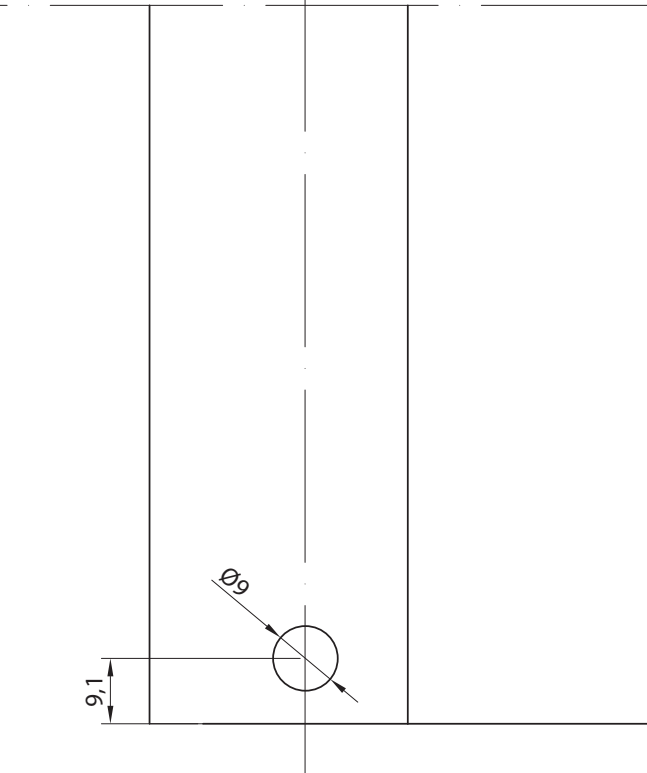
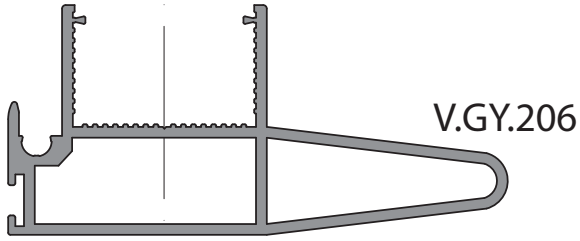
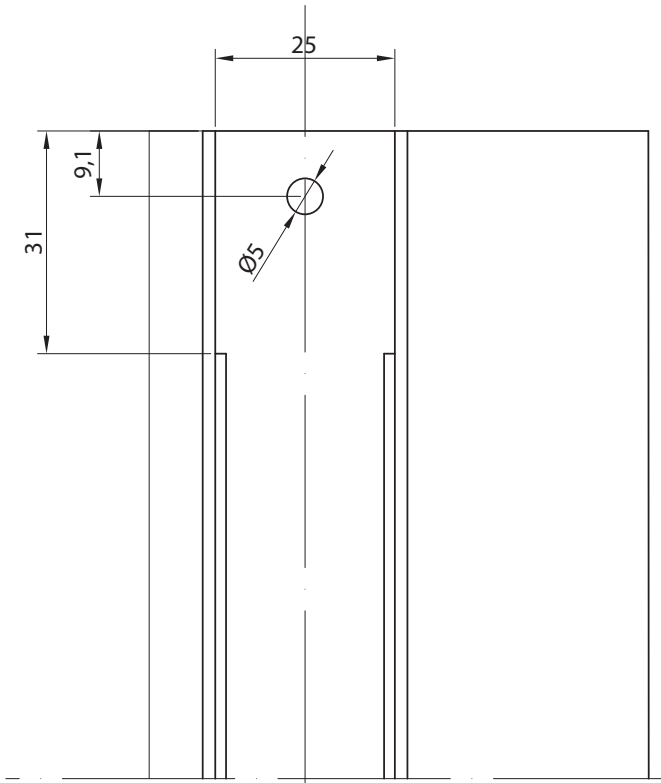

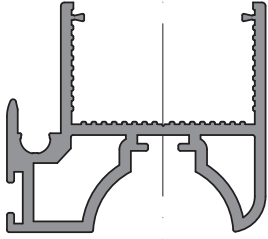
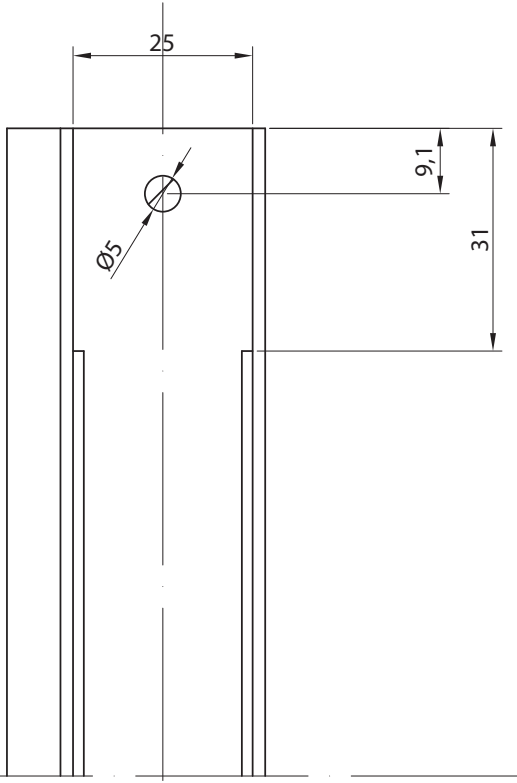

V.GY.209

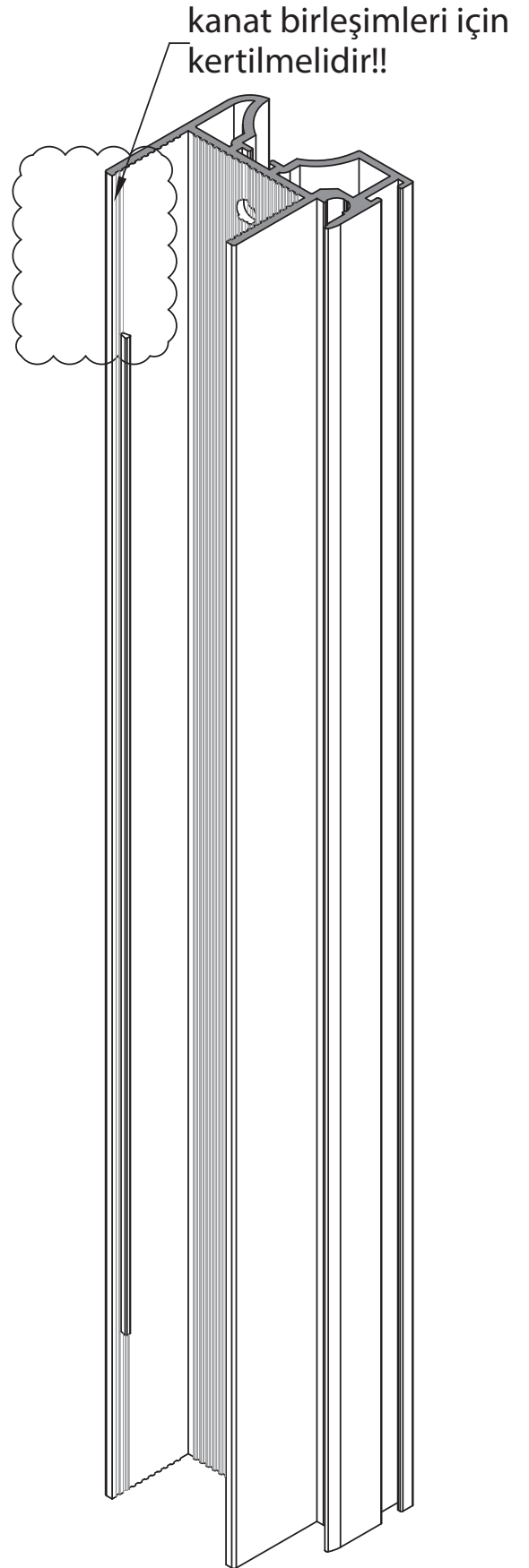

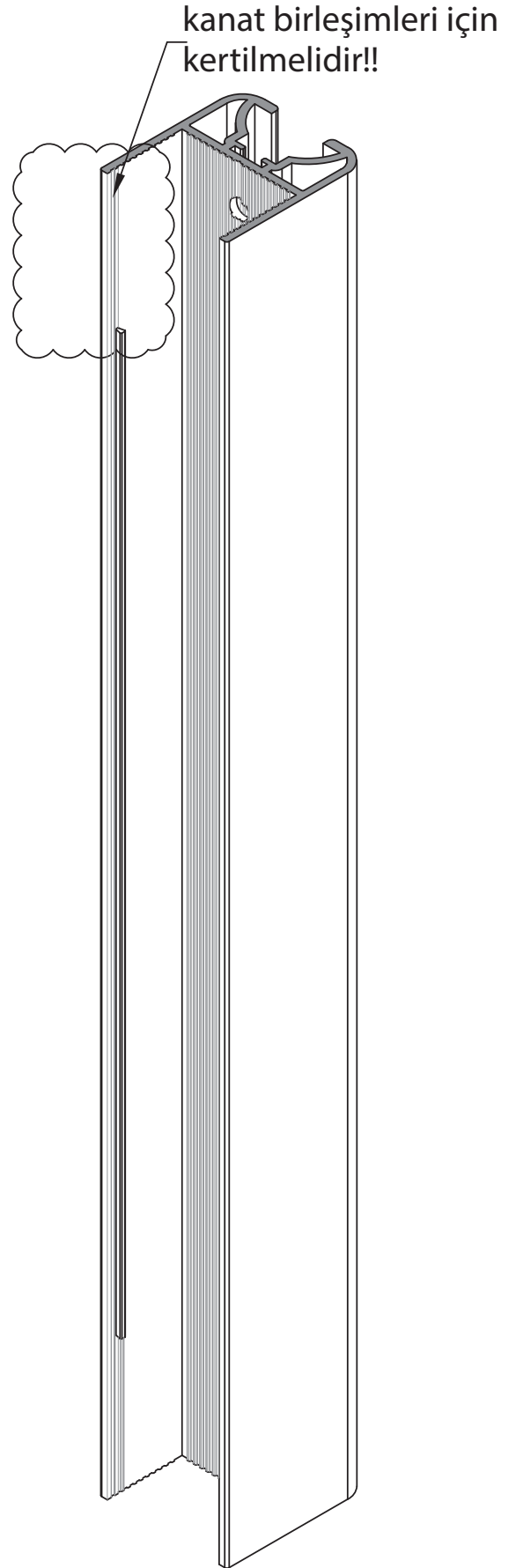
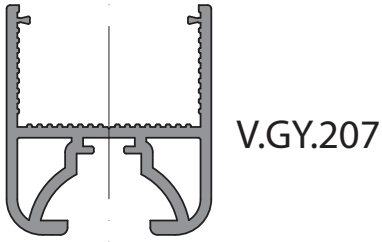
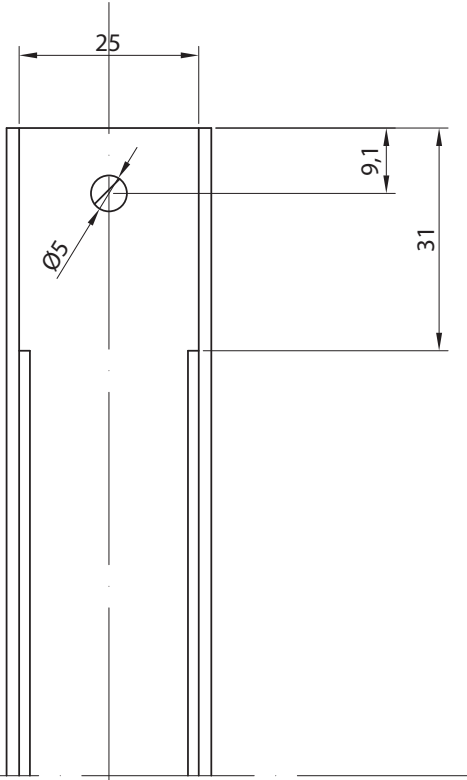

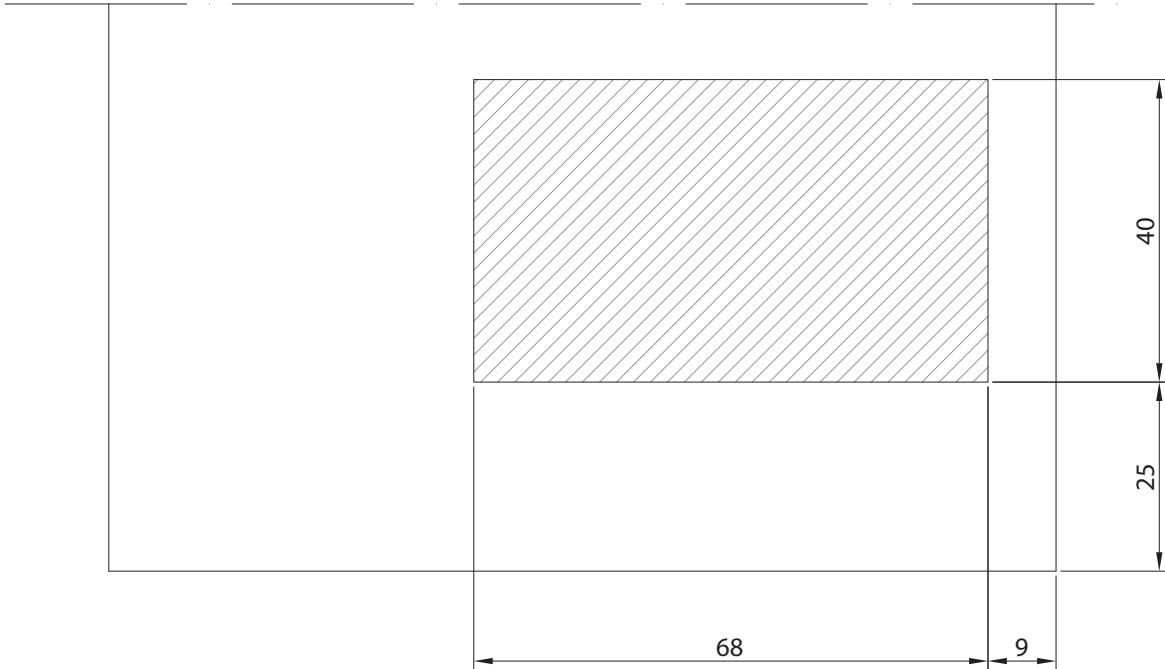
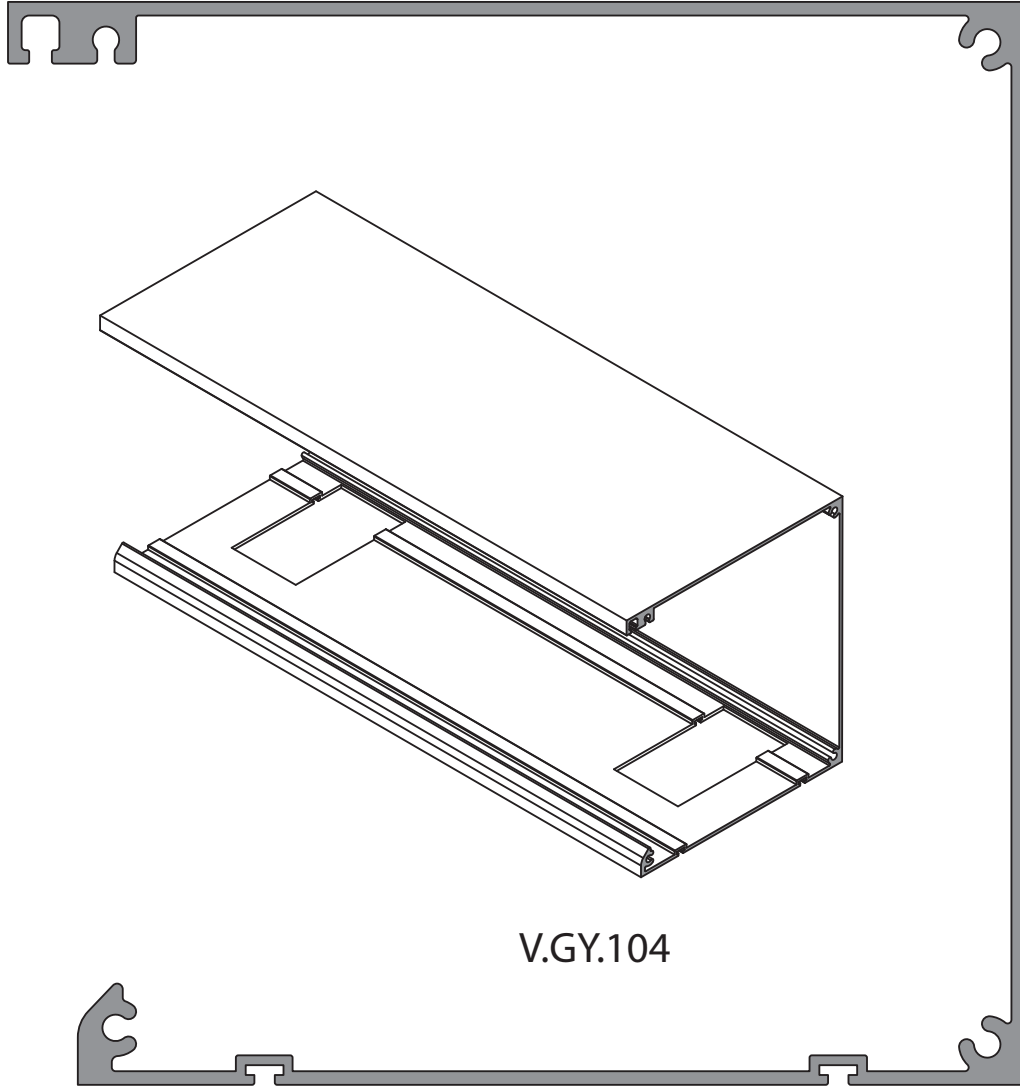

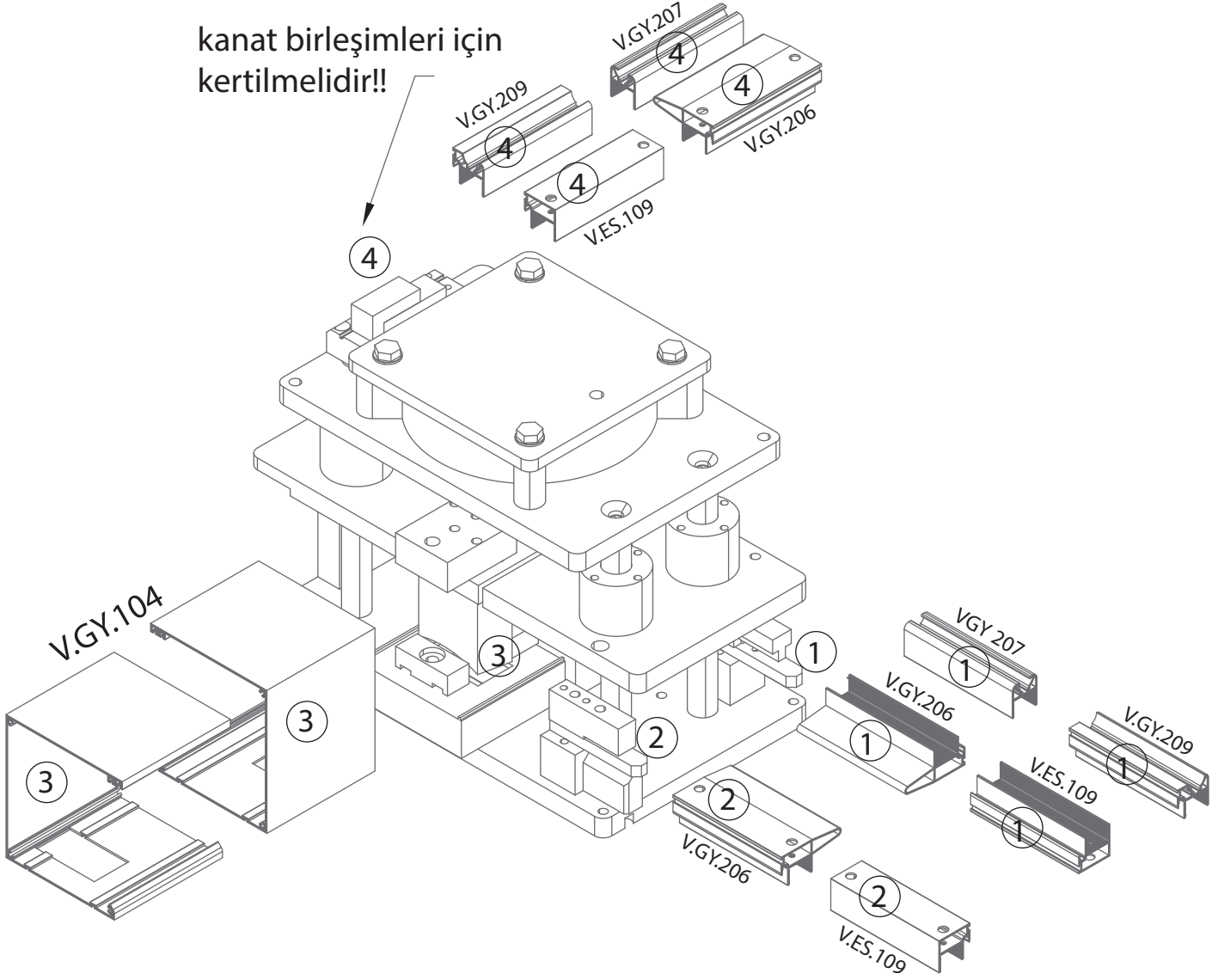

vetrina

Hareketli Panel Tavan Sistem

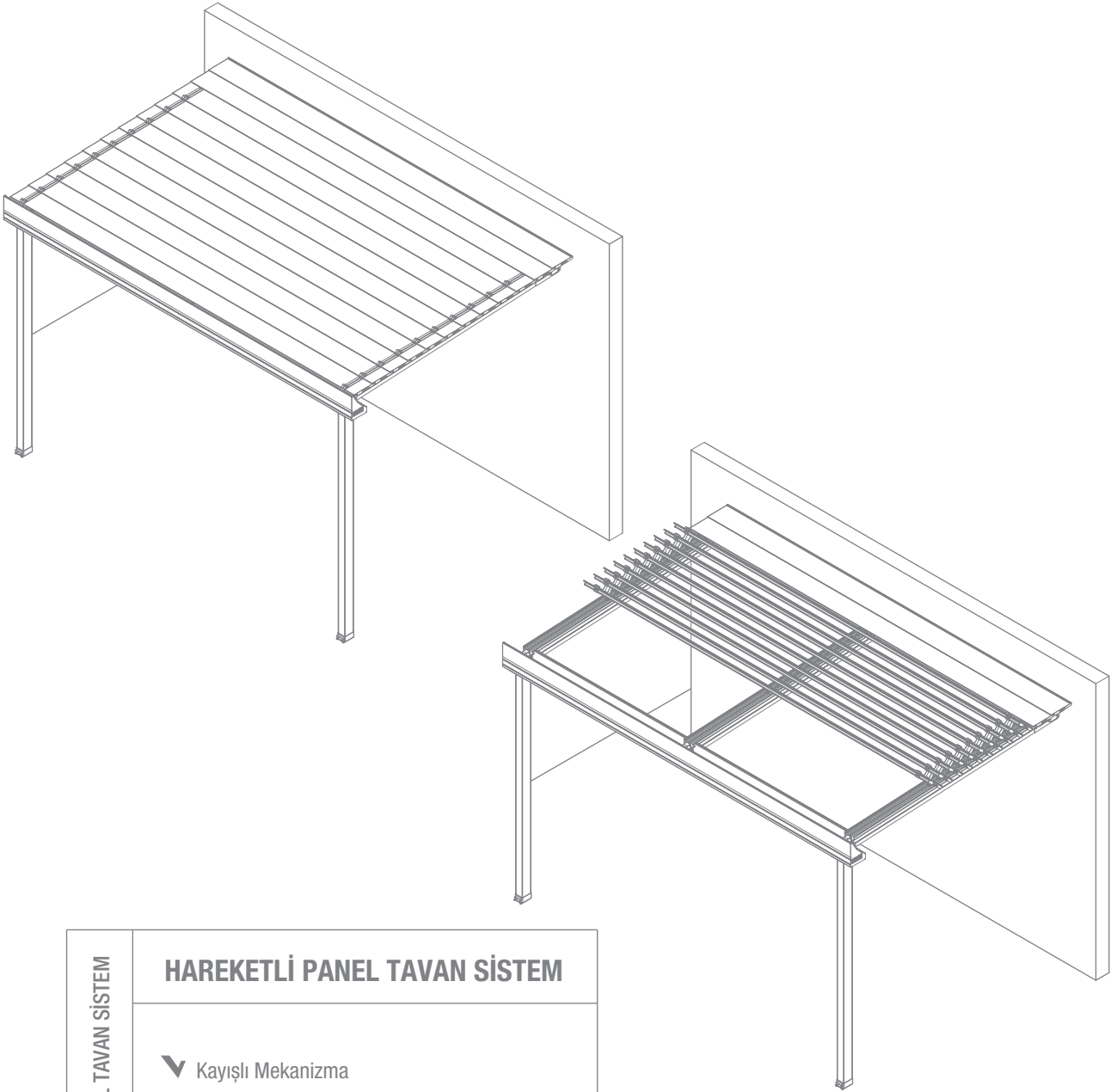

HAREKETLİ PANEL TAVAN SİSTEM

HAREKETLİ PANEL TAVAN SİSTEM

- ▼ Kayışlı Mekanizma
- ▼ Max. 50 m² alan
- ▼ Max. genişlik 800cm

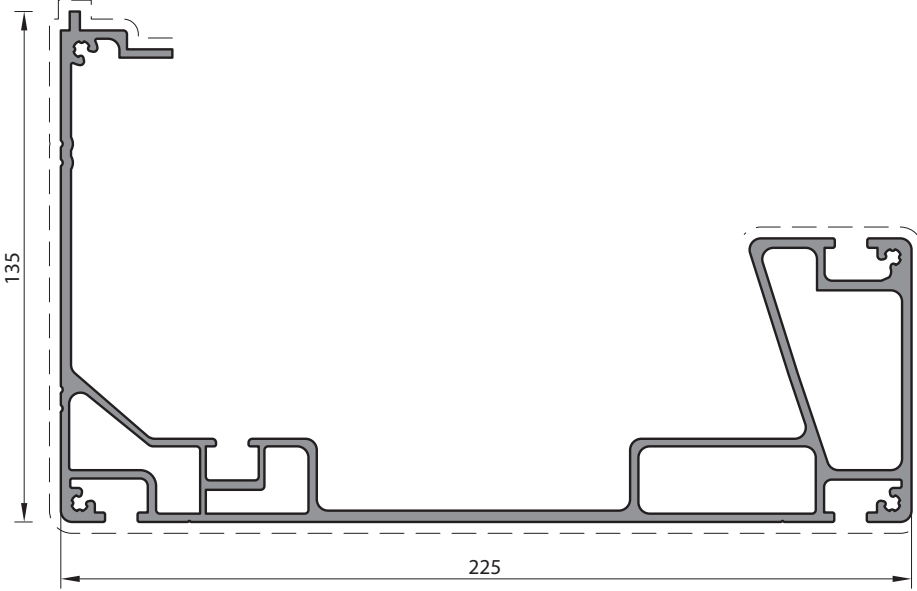

DERE PROFİLİ
3344
5.600 kg/mt

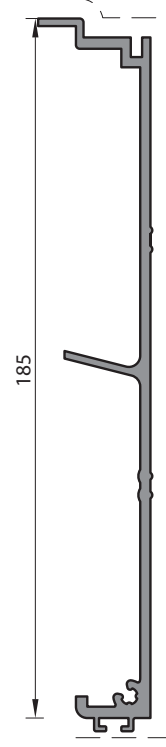

DERE KAPAK PROFİLİ
3345
1.950 kg/mt

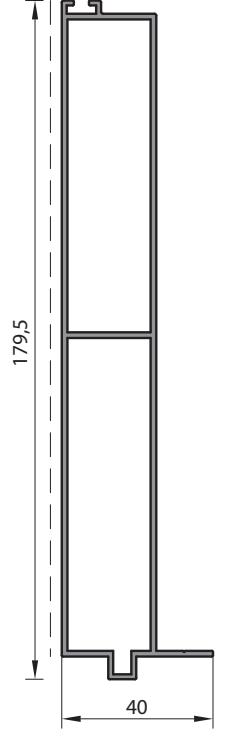

DERE İÇ KAPAMA PROFİLİ
8469
1.786 kg/mt

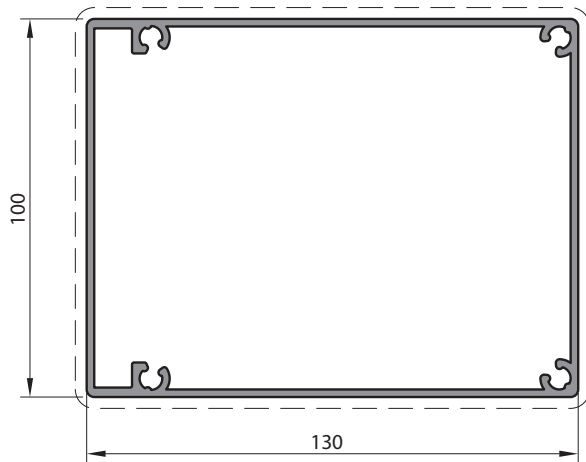

DİKME PROFİLİ
8471
2.767 kg/mt

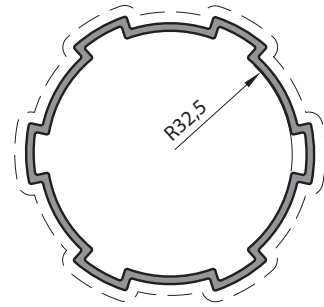

MOTOR BORU PROFİLİ
8470
1.426 kg/mt

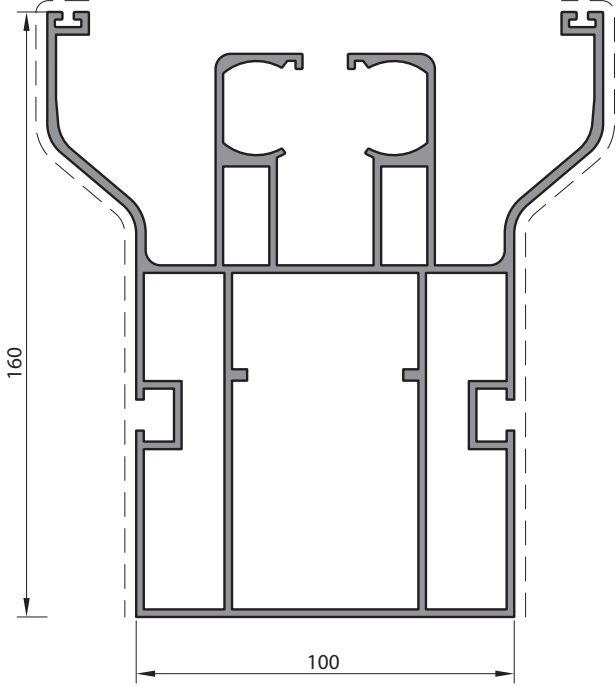

160 LIK RAY PROFİLİ
7384
6.058 kg/mt

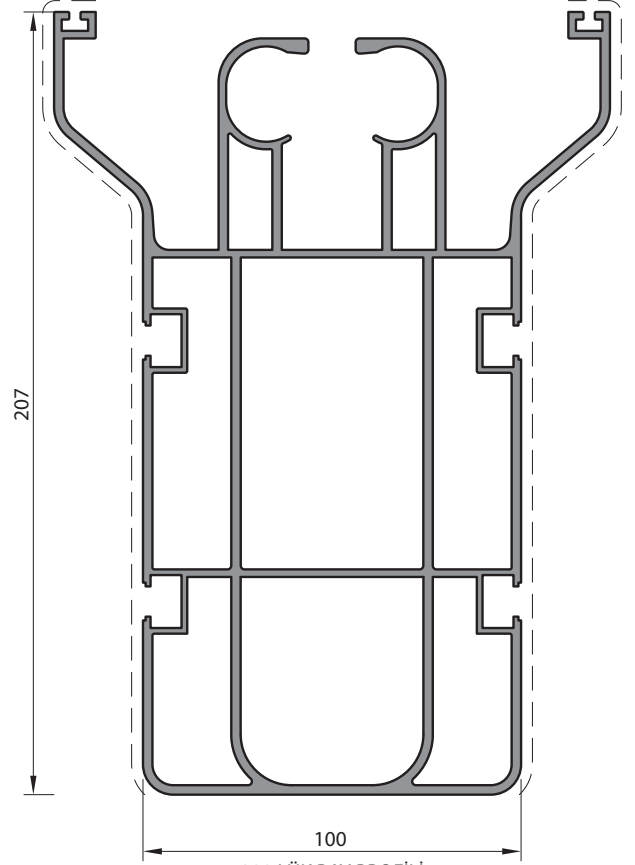

200 LÜK RAY PROFİLİ
7558
8.345 kg/mt

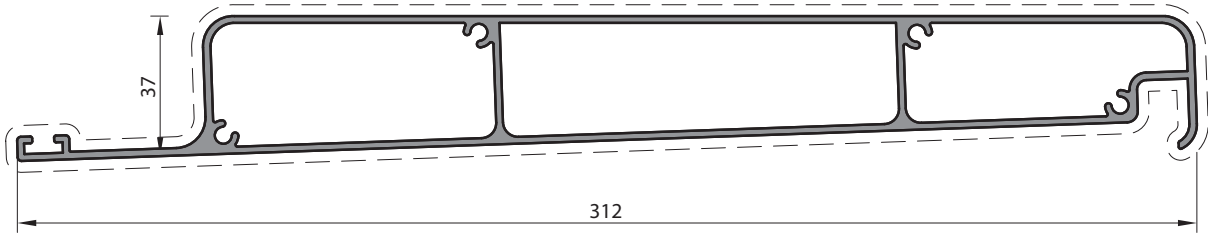

HAREKETLİ PANEL PROFİLİ
7383
3.833 kg/mt

KOD	ŞEKİL	TANIM	PAKET METRAJİ	KULLANIM YERİ
AKS-HP 01		Küçük Araba Takımı (PVC)	1 adet	
AKS-HP 02		Büyük Araba Takımı (PVC)	1 adet	
AKS-HP 03		Panel Kapak (Sağ-Sol) (PVC)	1 takım	
AKS-HP 04		Panel Yan Kapak (Sağ-Sol) (PVC)	1 takım	
AKS-HP 05		Büyük Makas (Çelik)	1 adet	
AKS-HP 06		Küçük Makas (Çelik)	4 adet	
AKS-HP 07		M12 pim	1 adet	
AKS-HP 08		Ray Ön Takım (PVC)	1 adet	
AKS-HP 09		Dere Yan Kapak (Çelik)	1 adet	

KOD	ŞEKİL	TANIM	PAKET METRAJİ	KULLANIM YERİ
AKS-HP 10		Panel Orta Mafsal (PVC)	1 adet	
AKS-HP 11		Kutu Profil Bağlantı Laması (Zamak)		
AKS-HP 12		Ray Profili Bağlantı Laması (Zamak)		
AKS-HP 13		Bağlantı Laması (Zamak)		
AKS-HP 14		Dere Bağlantı Flanşı (Alm.)		
AKS-HP 15		Dikme Profil Pabuç (Zamak)		
AKS-HP 16		Araba Sabitleme Sacı		
AKS-HP 17		Motor Bağlantı Takımı (PVC)		
AKS-HP 18		Motor Bağlantı Flanşı (Çelik)		

KOD	ŞEKİL	TANIM	PAKET METRAJİ	KULLANIM YERİ
AKS-HP 19		M12 Somunlu Vida		
AKS-HP 20		Motor Kapak (Pvc)		
AKS-HP 21		Triger Kayış		
Z-95		Hareketli Panel Fiteli (Epdm)	94 gr/m 160 m	
Z-96		Sabit Panel Fiteli (Epdm)	115 gr/m 130 m	
Z-97		Ray ve Dere İç Kapama Fiteli (Epdm)	163 gr/m 92	

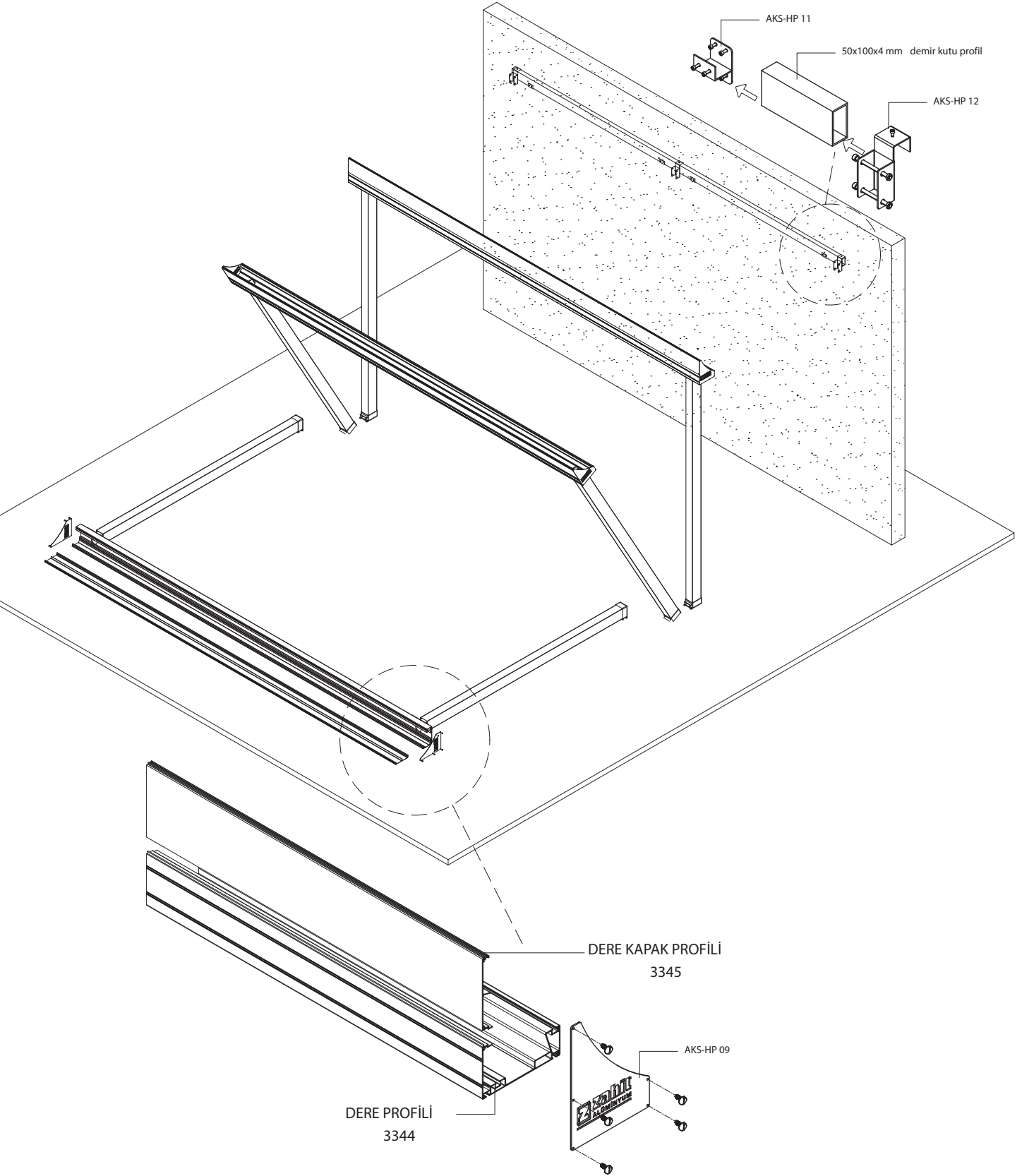

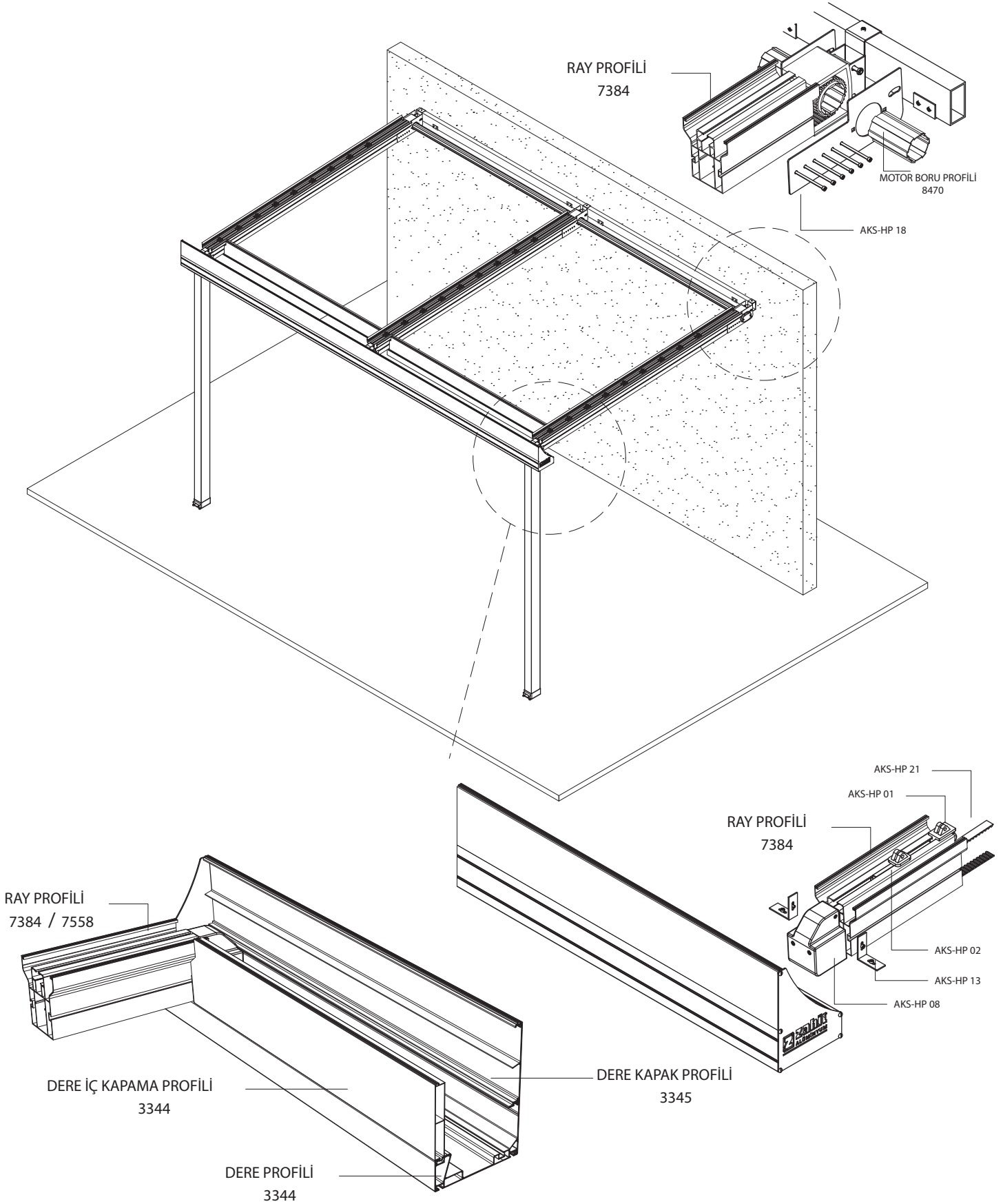

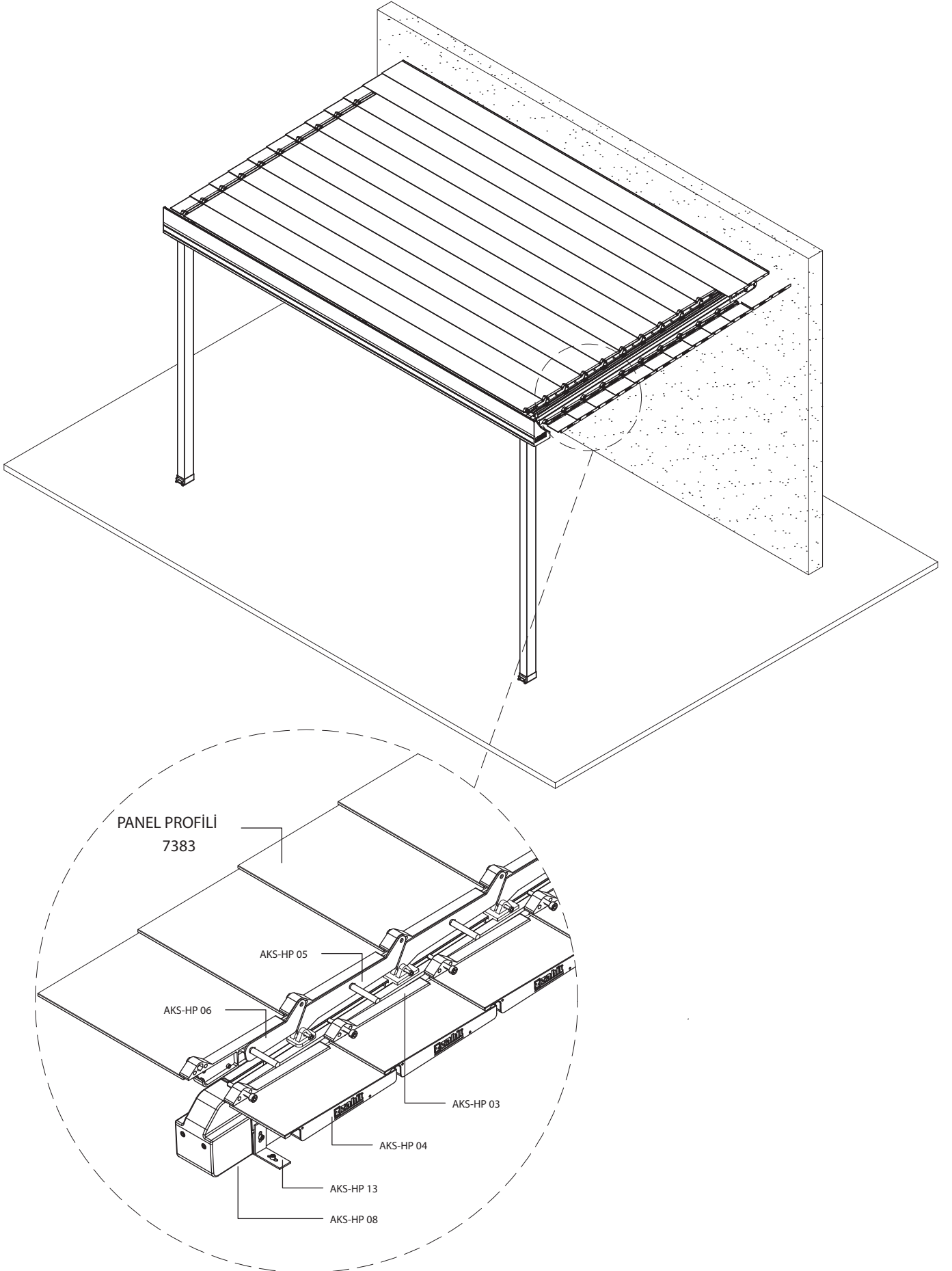

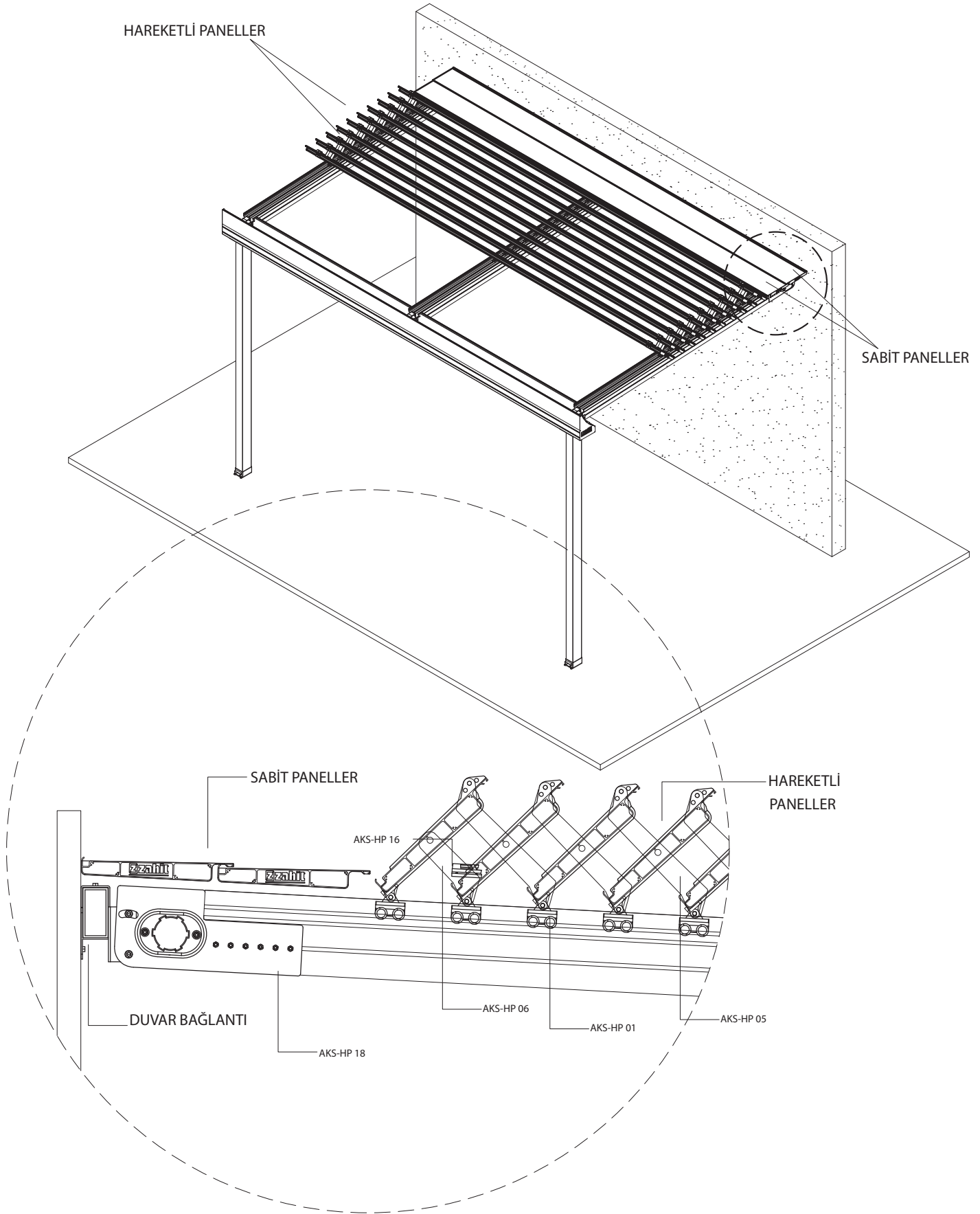

vetrina

Eco Slim Sürme Sistem

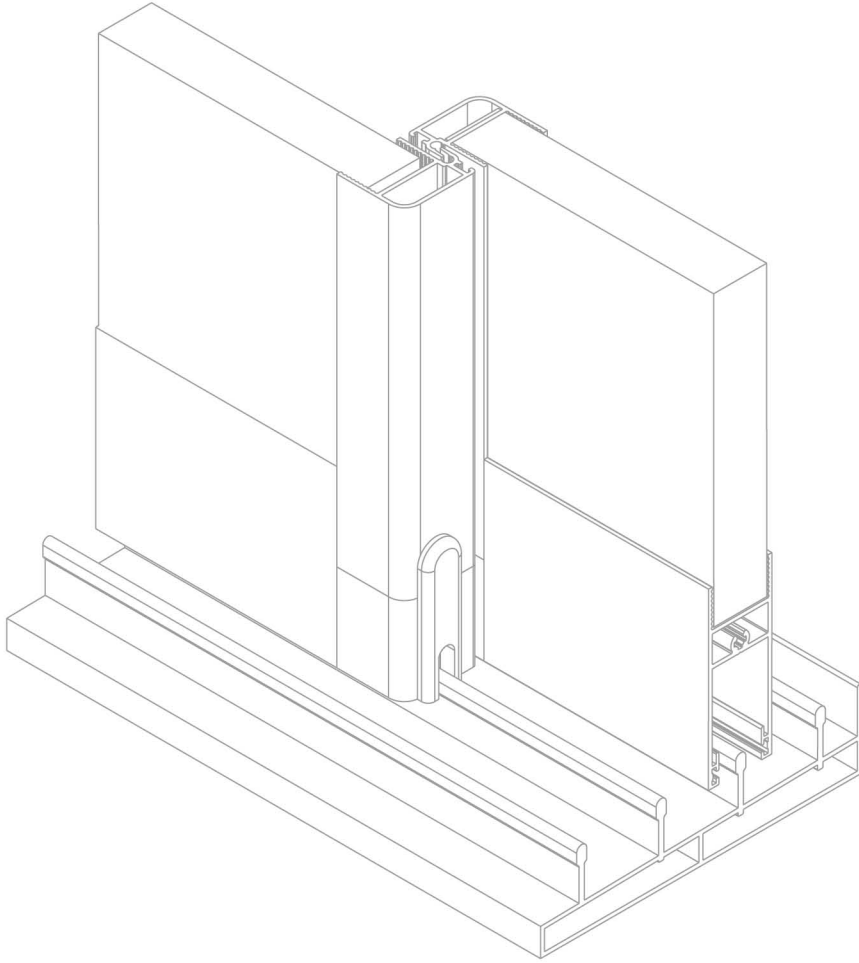

ECO SLIM SÜRME SİSTEM	ECO SLIM SÜRME SİSTEM	V.ES.	V.ES.	201
	<ul style="list-style-type: none">✓ Ekonomik, kolay montaj✓ Cam Özelliği; 6 mm, 8 mm, 10 mm ve 4 mm+12Hb+4 mm✓ Max. kanat ağırlığı : 120 kg		SİSTEM	PR NO

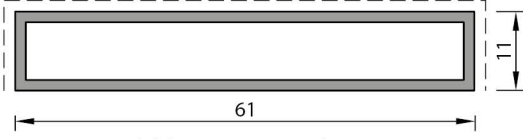

İKİLİ YAN KASA PROFİL
V.ES.221
0.519 kg/mt

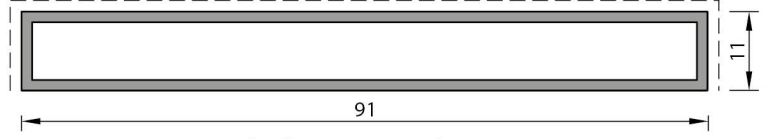

ÜÇLÜ YAN KASA PROFİL
V.ES.231
0.746 kg/mt

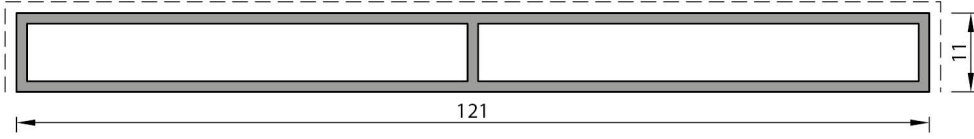

DÖRTLÜ YAN KASA PROFİL
V.ES.241
1.003 kg/mt

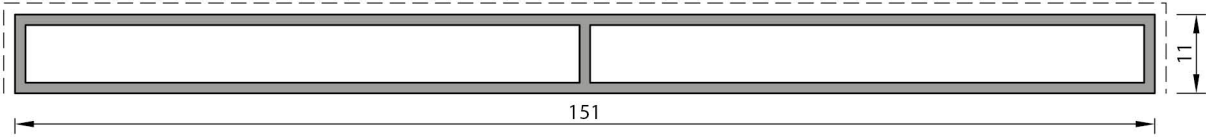

BEŞLİ YAN KASA PROFİL
V.ES.251
1.231 kg/mt

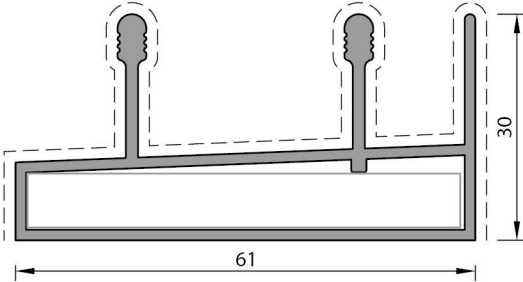

İKİ RAYLI PROFİL
V.ES.222
0.822 kg/mt

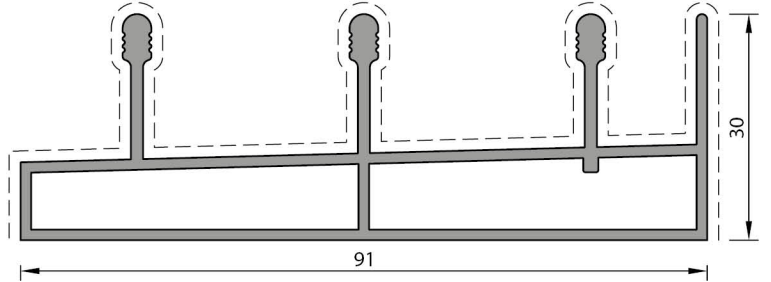

ÜÇ RAYLI PROFİL
V.ES.232
1.194 kg/mt

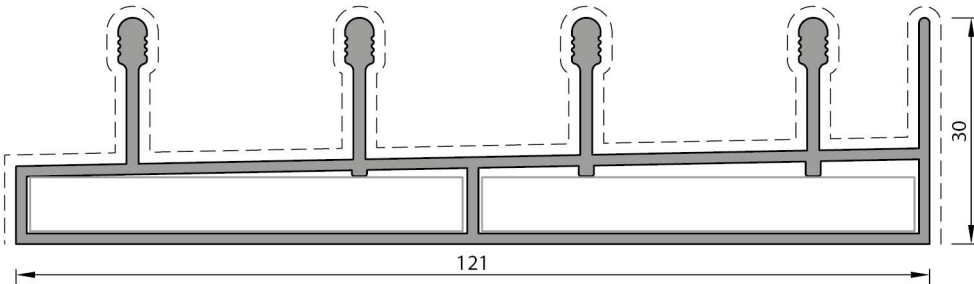

DÖRT RAYLI PROFİL
V.ES.242
1.554 kg/mt

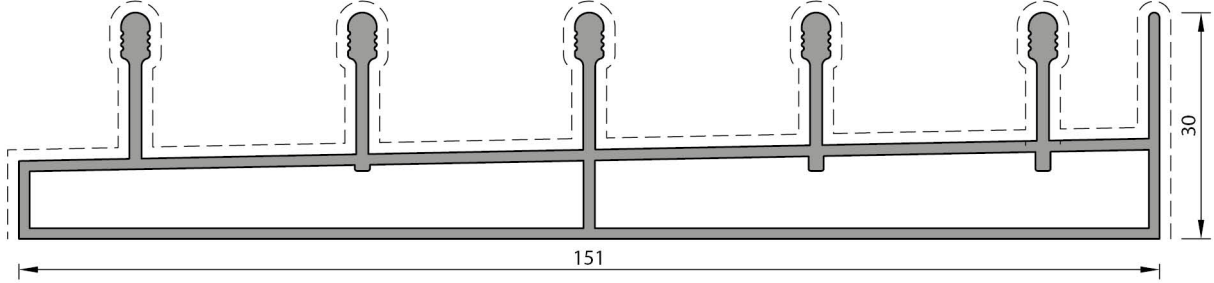

BEŞ RAYLI PROFİL
V.ES.252
1.900 kg/mt

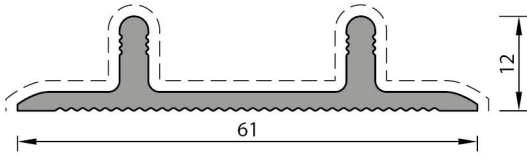

İKİ RAYLI EŞİKSİZ PROFİL
V.ES.223
0.570 kg/mt

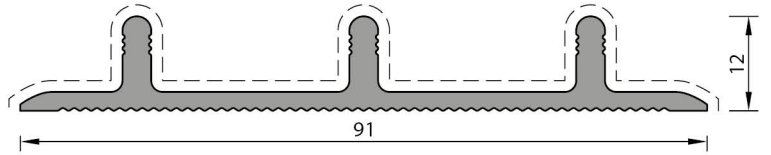

ÜÇ RAYLI EŞİKSİZ PROFİL
V.ES.233
0.857 kg/mt

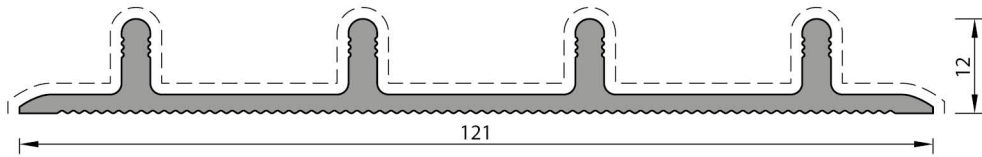

DÖRT RAYLI EŞİKSİZ PROFİL
V.ES.243
1.144 kg/mt

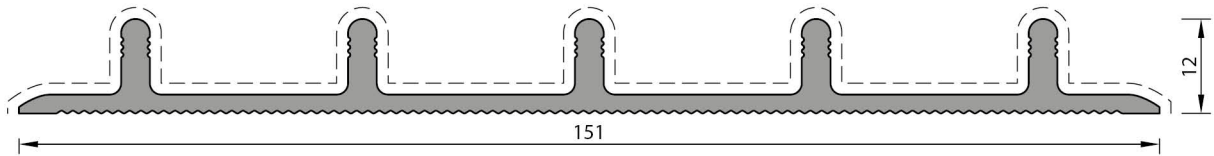

BEŞ RAYLI EŞİKSİZ PROFİL
V.ES.253
1.431 kg/mt

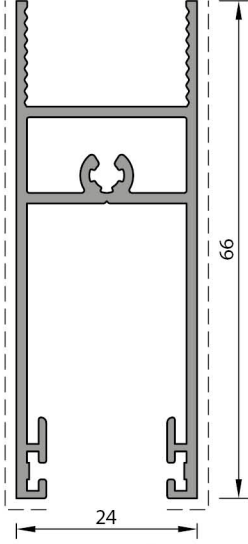

BAZA PROFİL
V.ES.261
0.761 kg/mt

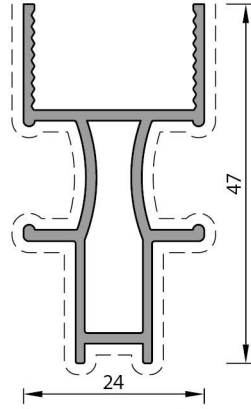

KOL BAZA PROFİL
V.ES.262
0.510 kg/mt

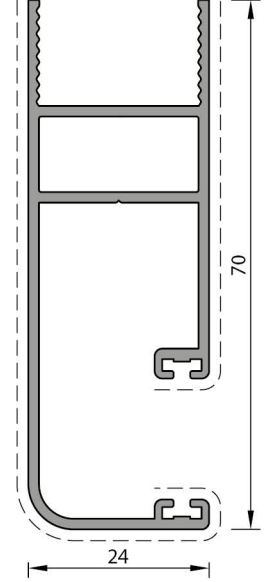

90° KÖŞE PROFİL
V.ES.263
0.738 kg/mt

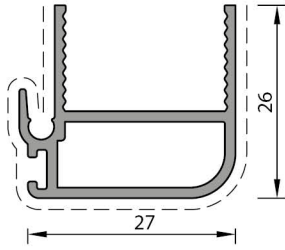

KENET PROFİL
V.ES.271
0.386 kg/mt

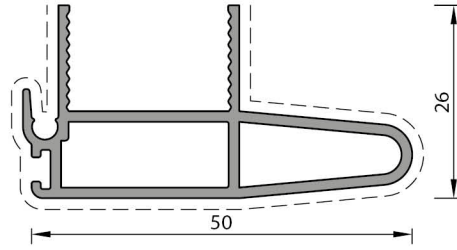

TAKVİYELİ KENET PROFİL
V.ES.272
0.577 kg/mt

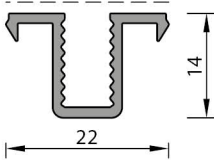

6 MM CAM ÇITA PROFİL
V.ES.296
0.177 kg/mt

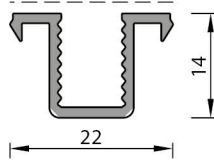



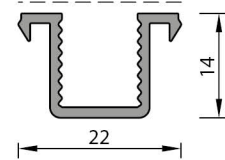

8 MM CAM ÇITA PROFİL
V.ES.298
0.178 kg/mt

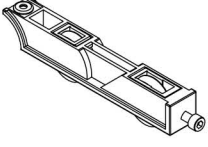
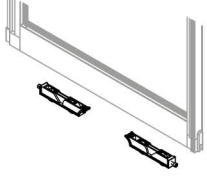

10 MM CAM ÇITA PROFİL
V.ES.290
0.179 kg/mt

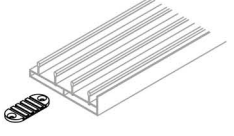
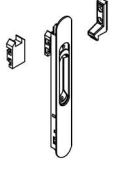
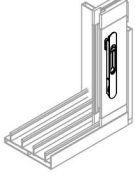
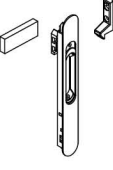
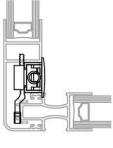
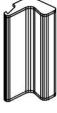
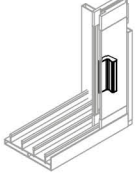
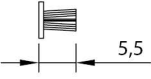
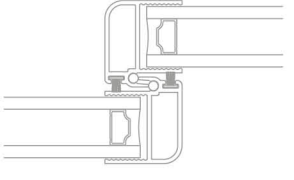
KOD	ŞEKİL	TANIM	PAKET METRAJİ	KULLANIM YERİ
ECS-02		2 li Kasa Köşe Takoğu (PVC)	4	
ECS-03		3 lü Kasa Köşe Takoğu (PVC)	4	
ECS-04		4 lü Kasa Köşe Takoğu (PVC)	4	
ECS-05		5 li Kasa vKöşe Takoğu (PVC)	4	
ECS-61		Kilit Takoğu (PVC)	2	
ECS-62		Kol Takoğu (PVC)	2	
ECS-63		90° Köşe Takoğu (PVC)	2	
ECS-71		Kenet Takoğu (PVC)	2	
ECS-72		Kenet Kapak (PVC)	2	

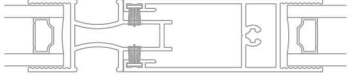
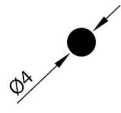
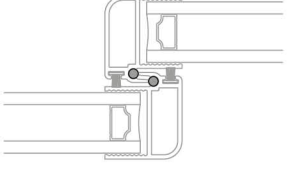
KOD	ŞEKİL	TANIM	PAKET METRAJİ	KULLANIM YERİ
ES-01		Ayarlı rulman	2	
ECS-13		2 li Kasa Köşe Takoğu	1	
ECS-14		Havuz kol kilitleme takımı	1	
ECS-15		Havuz kol kilitleme takımı	1	
ECS-16		Havuz kol kilitleme takımı	1	
ECS-17		Fırça Fiteli	400 m/pk	
ECS-18		Fırça Fiteli	400 m/pk	
W55.511		Epdm Kenet Fiteli	400 m/pk	

2 Ray

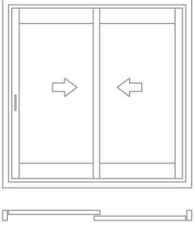

2 Ray

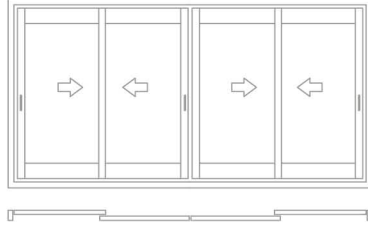

2-3-4-5 Ray

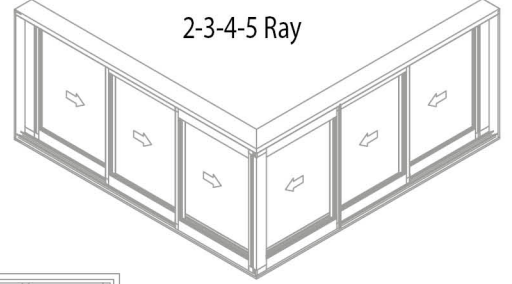

3 ray

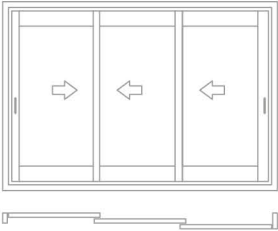

3 Ray

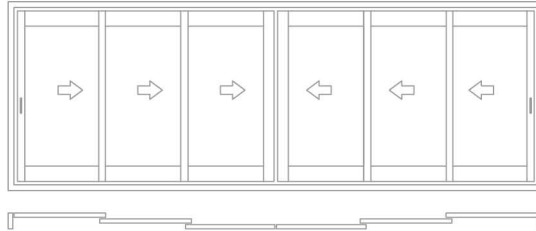

4 Ray

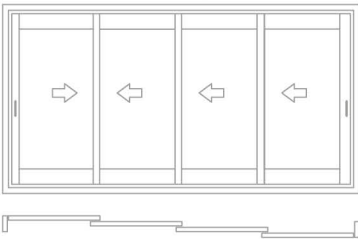

4 Ray

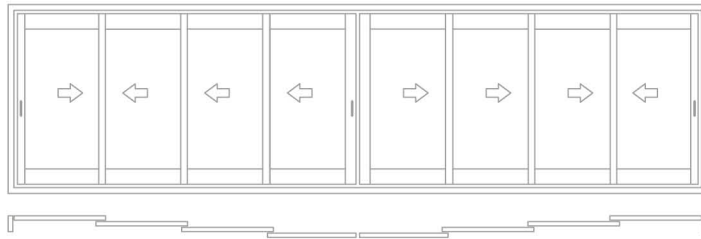

5 Ray

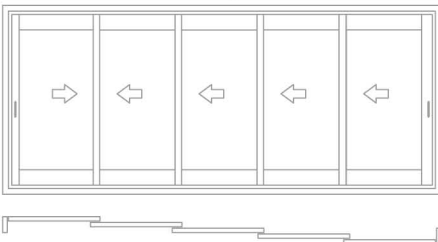

5 Ray

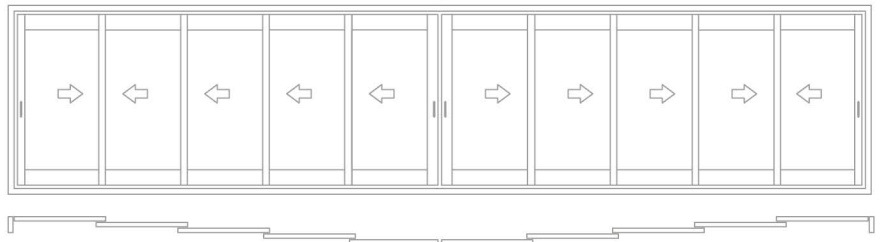

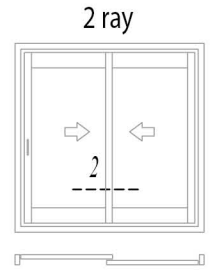
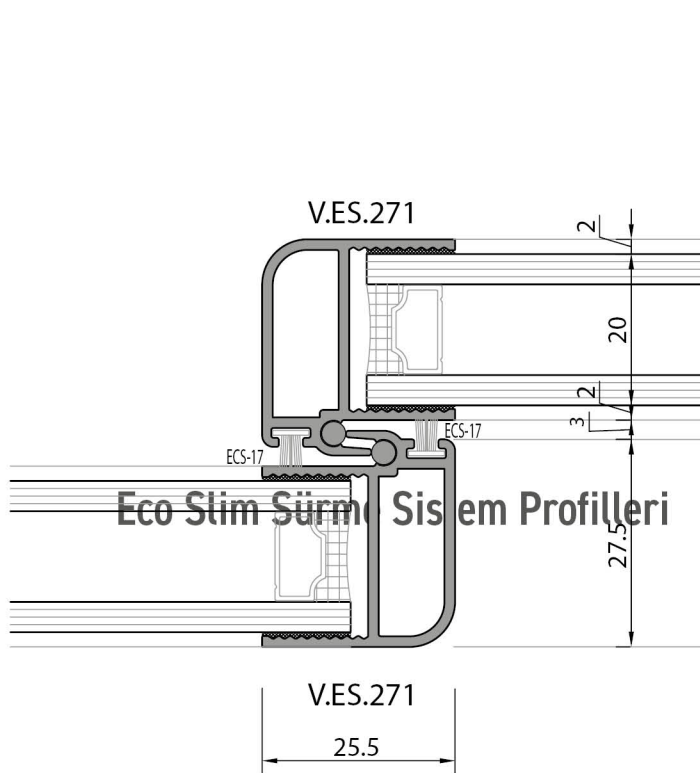
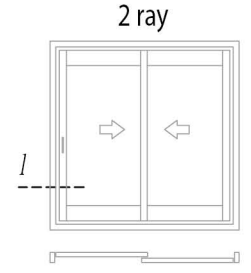
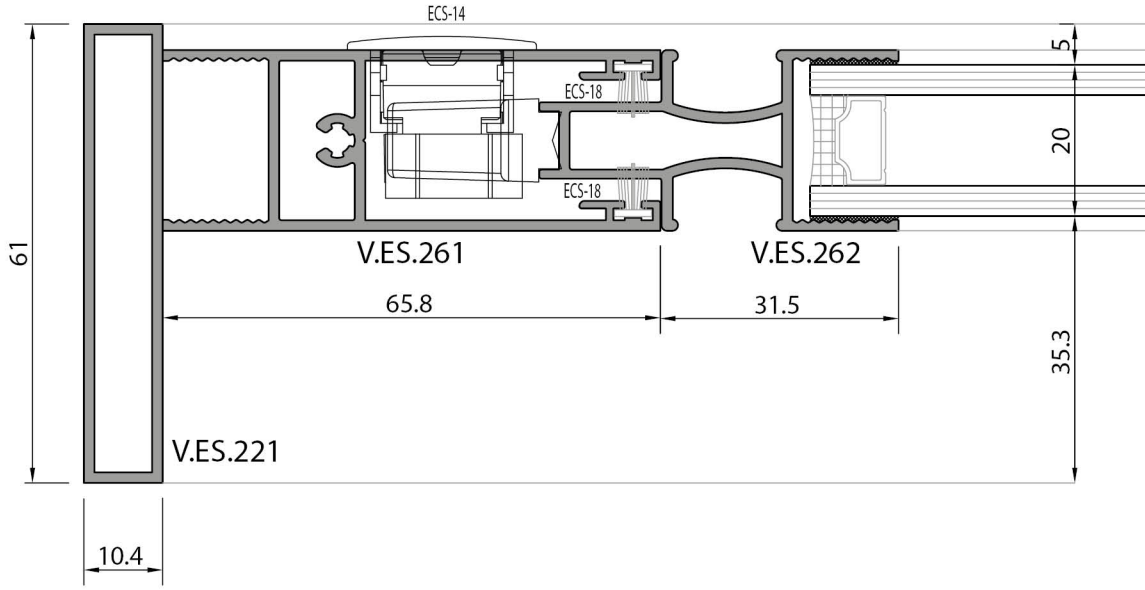

Eco Slim Sürme Sistem Profilleri

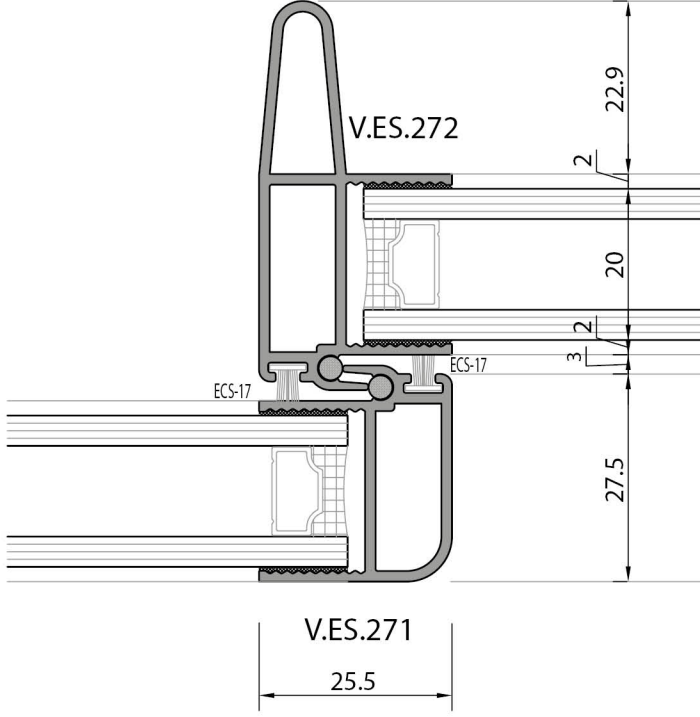

2 ray

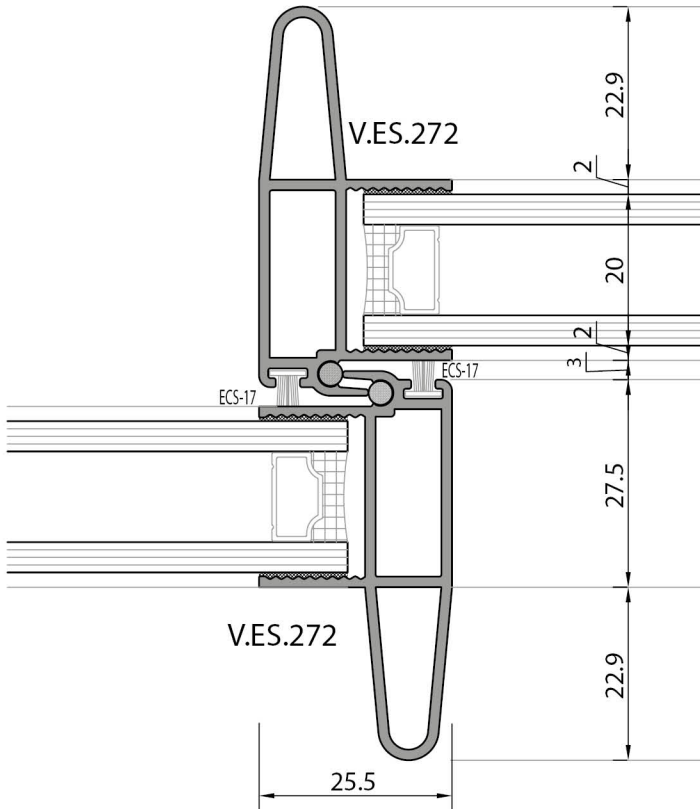
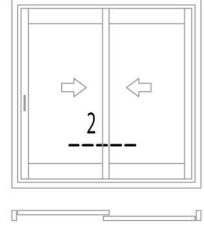

2 ray

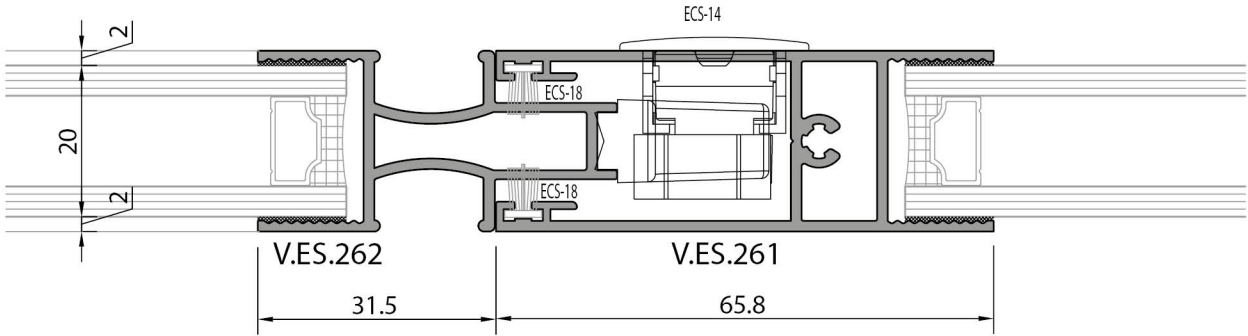
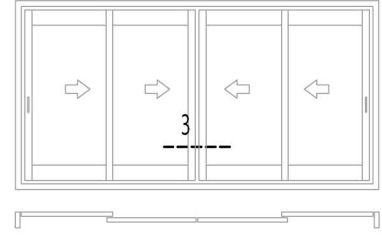

2 ray

